

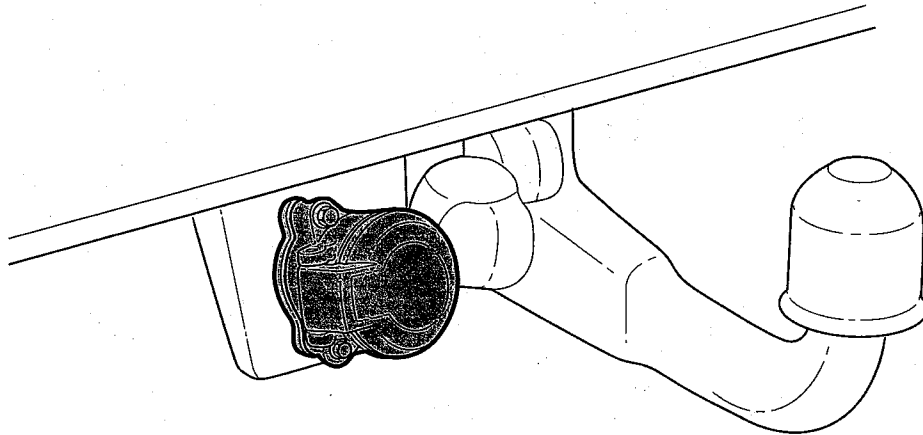



TRAILER TOW LIGHTING KIT (EMEA) JEEP WRANGLER

www.mopar.com



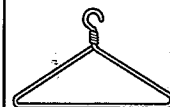
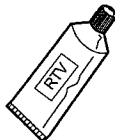
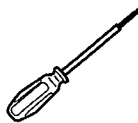
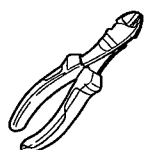
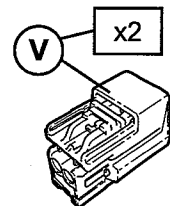
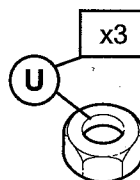
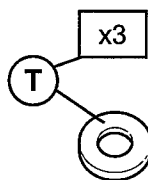
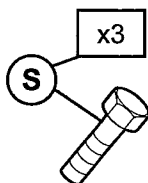
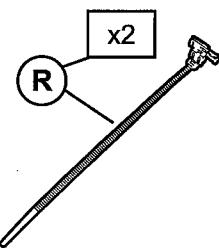
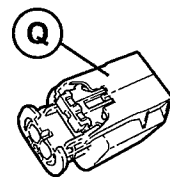
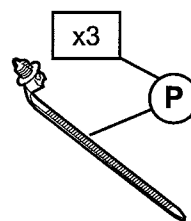
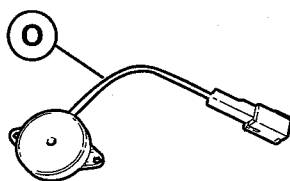
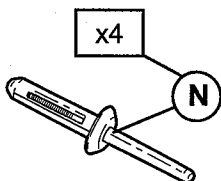
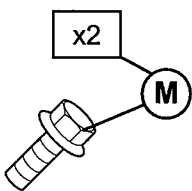
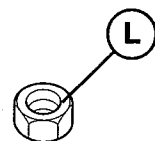
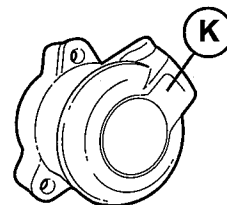
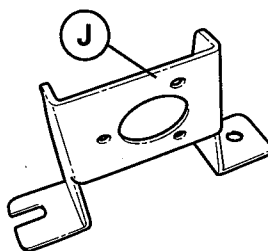
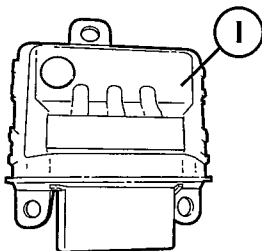
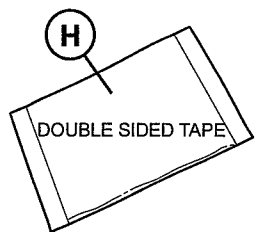
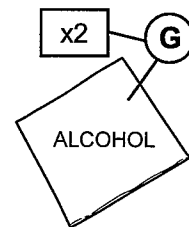
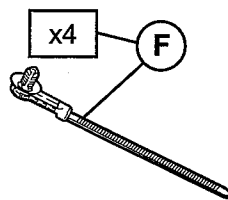
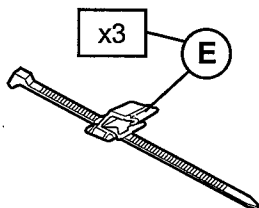
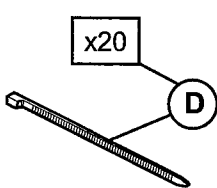
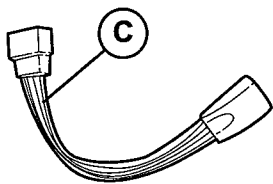
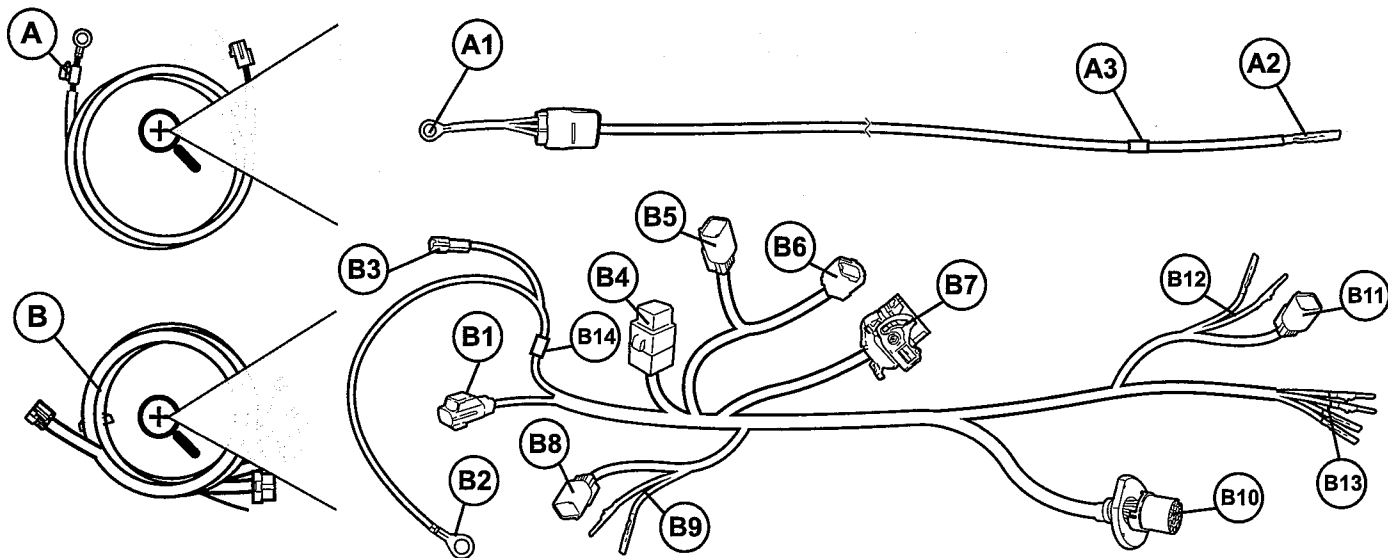























- EN** English - TRAILER TOW
- ES** Spanish - JUEGO DE ILUMINACIÓN DEL REMOLQUE DE TRÁILER
- FR** French - KIT ÉCLAIRAGE DE REMORQUE
- DE** German - BELEUCHTUNGSSET FÜR ANHÄNGERKUPPLUNGEN
- PT** Portuguese - KIT DE ILUMINAÇÃO DO GANCHO PARA REBOQUE
- GR** Greek - ΣΕΤ ΦΩΤΙΣΜΟΥ ΣΥΣΤΗΜΑΤΟΣ ΕΛΞΗΣ ΡΥΜΟΥΛΚΟΥΜΕΝΟΥ
- RU** Russian - КОМПЛЕКТ ОСВЕТИТЕЛЬНОГО ОБОРУДОВАНИЯ ДЛЯ ПРИЦЕПА
- ZH** Mandarin Traditional - 拖车照明套件
- KO** Korean - 트레일러 토우 조명 키트
- JA** Japanese - トレーラー牽引照明キット
- AR** Arabic (Saudi Arabia) - سحب المقطورة
- IT** Italian - GANCIO DI TRAINO
- TR** Turkish - RÖMORK ÇEKİCİ





abc	EN Description	ES Descripción	FR La description	DE Beschreibung	PT Descrição	
A	Power Harness	Cables de alimentación	Câble de transmission	Stromkabelbaum	Cabo de Alimentação	1
B	Main Harness	Juego de cables principal	Câble principal	Hauptkabelbaum	Cabo Principal	1
C	Left Tail Lamp Harness	Juego de cables de piloto trasero izquierdo	Câble feu arrière gauche	Kabelbaum für das linke Rücklicht	Cabo da Luz Traseira Esquerda	1
D	Tie Wrap	Brida de sujección	Collier	Kabelbinder	Cinta	20
E	Edge Biter Clip	Clip eliminador de borde	Clip de serrage pour bord	Kantencлип	Clipe de Aperto da Extremidade	3
F	Offset Xmas Tree Clips	Clips tipo árbol de Navidad	Clips offset à pied sapin	Offset-Tannenbaumclips	Clipes Offset da bucha	4
G	Cleaning Pad	Almohadilla limpiadora	Tampon nettoyant	Reinigungspad	Esponja de Limpeza	2
H	Double Sided Tape	Cinta de doble cara	Adhésif double face	Doppelseitiges Klebeband	Fita de Dupla Face	1
I	EMEA ECU	EMEA ECU	EMEA ECU	EMEA Steuergerät	ECU EMEA	1
J	13 Way Trailer Bracket	Soporte de remolque de 13 vías	Support 13 plots pour remorque	13-poliger Anhängerbock	Suporte de Reboque de 13 Vias	1
K	13 Way Trailer Socket	Terminal de remolque de 13 vías	Douille 13 plots pour remorque	13-polige Anhängersteckdose	Ranhura para Reboque de 13 Vias	1
L	PDC Nut	Tuerca PDC	Écrou PDC	PDC Mutter	Porca PDC	1
M	Bolt Bracket	Perno de autobloqueo	Support boulon	Stiftklemme	Suporte do Parafuso	2
N	Rivets	Remaches	Rivets	Nieten	Rebites	4
O	Buzzer	Zumbador	Avertisseur	Summer	Campainha	1
P	Xmas Tree Tie Strap	Tirante de amarre tipo árbol de Navidad	Collier de serrage sapin	Tannenbaum Spanngurt	Cinta para Prender a Bucha	3
Q	Main Inline Connector	Conector de entrada principal	Connecteur in-line principal	Haupteingangsanschluss	Conector Principal Integrado	1
R	T-Slot Connector Clip	Clip de conector con ranura	Clip connecteur rainure en T	T-Nut Verbindungsclip	Clipe do Conector da Ranhura T	2
S	Pan Head Bolt	Tornillo de cabeza plana	Écrou tête cylindrique	Flachkopfschraube	Parafuso de Cabeça Cilíndrica	3
T	MS Flat Washer	Arandela plana MS	Rondelle plate MS	MS Unterlegscheibe	Anilha Lisa MS	3
U	Nut Bracket	Tuerca autoblocante	Support d'écrou	Rändelmutter	Suporte da Porca	3
V	Fog Lamp Inline Connector	Conector de entrada de luz antiniebla	Connecteur in-line feu antibrouillard	Eingangsanschluss Nebelscheinwerfer	Conector Integrado da Luz de Nevoeiro	2

abc	GR Περιγραφή	RU Описание	ZH 说明	KO 설명	JA 説明	
A	Δείκτη καλωδίων τροφοδοσίας ισχύος	Пучок питания	动力线束	파워 하니스	電力線ハーネス	1
B	Κύρια δέσμη καλωδίων	Главный жгут	主线束	메인 하니스	메인·ハーネス	1
C	Δείκτη καλωδίων αριστερού φανού	Жгут заднего фонаря	左尾灯线束	왼쪽 테일 램프 하니스	左側トレイルランプ・ハーネス	1
D	Δείκτης καλωδίων	Кабельная стяжка	綁扎帶	케이블 타이	結束帶	20
E	Γωνιακό κλιπ συγκράτησης	Фиксатор кабелей	緣齿夹	에지 바이더 클립	에지클리프	3
F	Κιρτά κλιπ συγκράτησης σχήματος χριστουγεννιάτικου δέντρου	Фиксатор «елочка»	聖誕樹分支夾	오프셋 크리스마스 트리 클립	오프셋 크리스마스 트리-형클리프	4
G	Επίθεμα καθαρισμού	Чистящая салфетка	清潔墊	클리닝 패드	클리닝패드	2
H	Ταινία διπλής όψευς	Двухсторонняя лента	双面膠帶	양면테이프	両面テープ	1
I	Μονάδα ελέγχου κινητήρα (ECU) EMEA	ЭБУ для Европы, Ближнего Востока и Африки	EMEA ECU	EMEA ECU	EMEA用ECU (엔진컴퓨터로봇유닛)	1
J	Βραχίονας ρυθμιζόμενου 13 διαβρώσεων	Кронштейн сцепного устройства с 13 контактами	13路拖車托架	13식 트레일러 브라켓	13웨이트레일러-브라켓	1
K	Ρυθμιζόμενης ρυθμιζόμενου 13 διαβρώσεων	Гнездо сцепного устройства с 13 контактами	13路拖車插座	13식 트레일러 소켓	13웨이트레일러-소켓	1
L	Περικόχλιο PDC	Гайка PDC	PDC螺母	PDC 너트	PDC Nut	1
M	Βραχίονας στήριξης κοχήλια	Болт кронштейна	托架螺栓	볼트 브라켓	볼트브라켓	2
N	Πριτσίνα	Заклепки	铆釘	리벳	리벳	4
O	Βομβητής	Гудок	蜂鸣器	버저	부저	1
P	Ιμάντας προώθησης σχήματος χριστουγεννιάτικου δέντρου	Стяжка «елочка»	聖誕樹綁扎帶	크리스마스 트리 타이 스트랩	크리스마스 트리-형結束밴드	3
Q	Κύριος σύνδεσμος σε σειρά	Главный линейный соединитель	主线内联连接器	메인 인라인 커넥터	메인 직렬코넥타	1
R	Ακροδέκτης σύνδεσης με σχισμή σχήματος T	T-образный зажим соединителя	T-型槽连接器夹	T슬롯 커넥터 클립	T스ล็อต코넥타클리프	2
S	Κοχήλια με κεφαλή οριζόντιας περιστροφικής κίνησης	Болт с низкой конической головкой	截锥头螺栓	냄비머리 볼트	냄비머리볼트	3
T	Επίπεδη ροδέλα MS	Плоская шайба MS	MS平墊圈	MS 평 와셔	MS 平ワッシャー	3
U	Βραχίονας στήριξης περικοχλίου	Гайка кронштейна	托架螺母	너트 브라켓	너트브라켓	3
V	Σύνδεσμος σε σειρά φανού ομίχλης	Линейный соединитель противотуманной фары	雾灯内联连接器	안개등 인라인 커넥터	안개등 직렬코넥타	2

abc	SA الوصف	IT Descrizione	TR Açıklama	
A	أ حزمة أسلاك	Cablaggio elettrico	Güç Kablosu	1
B	ب حزمة الأسلاك الرئيسية	Cablaggio principale	Ana Kablo	1
C	ج حزمة أسلاك مصباح الإنارة الخلفية الأيسر	Cablaggio del fanale posteriore sinistro	Sol Arka Lamba Kablosu	1
D	د حزمة حبل ربط	Fascetta	Kayış	20
E	ه مشبك حافة الوصلة	Fascetta con clip stringicavo	Uç Tutucu Klips	3
F	و عروات متفرعة ملتوية	Fermi a pressione sfalsati	Ofset Xmas Tırtıklı Klips	4
G	ز وسادات تنظيف	Panno di pulizia	Temizleme Pedi	2
H	ح شريط مزدوج الجوانب	Nastro biadesivo	Çift Taraflı Bant	1
I	ط الإكوادور وأوروبا والمشرق الأوسط وأفريقيا	EMEA ECU	EMEA ECU	1
J	ي 13 حاملة مصابيح المقطورة الخرجية	Staffa del rimorchio 13 Way	13 Yollu Römork Bağlantı Ayağı	1
K	ك 13 مقبس مصابيح المقطورة الخرجية	Presa del rimorchio 13 Way	13 Yollu Römork Soketi	1
L	ل صامولة PDC	Dado PDC	PDC Somun	1
M	م كتيفة براعي	Vite della staffa	Cıvata Bağlantısı	2
N	ن مسامير برشام	Rivetti	Perçinler	4
O	س جرس	Cicalino	Zil	1
P	ع شريط ربط ملتوي	Fascetta con fermo a pressione	Tırtıklı Bağlantı Bantları	3
Q	ف موصل مضمن رئيسي	Connettore principale in linea	Ana Sıralı Konektör	1
R	ص عروة ذات فتحات على شكل حرف T	Fascetta del connettore con scanalatura a T	T Yuvalı Konektör Klipsi	2
S	ق مسامير ملولب مستدير الرأس	Vite a testa bombata	Pan Başlı Cıvata	3
T	ر حلقة للأغراض العسكرية	Rondella piatta MS	MS Yassı Rondela	3
U	ش كتيفة صواميل	Dado della staffa	Somun Bağlantısı	3
V	ت موصل مضمن بمصباح الضباب	Connettore fendinebbia in linea	Sis Lambası Sıralı Konektörü	2

	EN	ES	FR	DE
	Position / location	Posición / ubicación	Position / emplacement	Position / lage
	Movement	Sentido del movimiento	Mouvement	Bewegung
	Disconnect / detach	Desconectar / quitar	Déconnecter / détacher	Abklemmen / abtrennen
	Connect / attach	Conectar / poner	Connecter / attacher	Anschließen / verbinden
	Left & right side of the vehicle	Lado izquierdo y derecho del vehículo	Côté gauche et droit du véhicule	Linke & rechte Seite des Fahrzeugs
	Check / do the functional testing	Comprobar / realizar la prueba de funcionamiento	Vérifier / effectuer le test technique	Prüfen / Funktionstest durchführen
	See workshop manual	Consultar el manual del taller	SE RÉFÉRER AU MANUEL D'ATELIER	SIEHE WERKSTATTHANDBUCH
	Attention / important advice	Atención / aviso importante	Attention/ mise en garde	ACHTUNG / WICHTIGER HINWEIS
	Present / occupied / OK	Disponible / ocupado / OK	Présent / occupé / OK	Vorhanden / belegt / OK
	Not present / not occupied / not OK	Ausente / no ocupado / mal	Non présent / non occupé / non OK	Nicht vorhanden / nicht belegt / nicht OK
	Tail light / tail lamp	Luz trasera / bombilla trasera	Lumière arrière / lampe arrière	Rücklicht / Rückleuchte
	Stop light	Semáforo	Feu de stop	Bremslicht
	Left turn signal indicator	Intermitente izquierdo	Indicateur clignotant gauche	Linker Fahrrichtungsanzeiger
	Right turn signal indicator	Intermitente derecho	Indicateur clignotant droit	Rechter Fahrrichtungsanzeiger
	Rear fog light(s)	Luces antiniebla traseras	Feu(x) antibrouillard arrière	Nebelschlussleuchte(n)
	Reversing light (s)	Luces de marcha atrás	Feu(x) marche arrière	Rückfahrleuchte(n)
	Ground or Earth (31)	Suelo o tierra (31)	Sol ou terre (31)	Masse oder Erdung (31)
	Standard	Estándar	Standard	Standard
	Optional / option	Opcional / opción	Facultatif / option	Optional/Option
	inside / from the inside	Interior / desde el interior	Intérieur / de l'intérieur	Innen / von innen
	outside / from the outside	Exterior / desde el exterior	Externe / de l'extérieur	Außen / von außen
	Left-hand drive vehicle	Vehículo con volante a la izquierda	Véhicule avec conduite à gauche	Linkslenker
	Right-hand drive vehicle	Vehículo con volante a la derecha	Véhicule avec conduite à droite	Rechtslenker
	Torque	Par de torsión	Couple	Drehmoment
	Quantity	Cantidad	Quantité	Anzahl

	PT	GR	RU
	Posição / Localização	Βέλος θέσης	Позиция / размещение
	Movimento	Βέλος κίνησης	Движение
	Desligar / separar	Αποσύνδεση / απόσπαση	Отсоединить
	Ligar / unir	Σύνδεση/ πρόσδεση	Присоединить
	Lados esquerdo e direito do veículo	Αριστερή και δεξιά πλευρά οχήματος	Левая и правая стороны автомобиля
	Verificar / executar o teste funcional	Έλεγχος / διεξαγωγή λειτουργικής δοκιμής	Проверить / выполнить функциональное тестирование
	CONSULTE O MANUAL DA OFICINA	Βλ. εγχειρίδιο εργαστηρίου	См. руководство пользователя
	Atenção / aviso importante	Προσοχή / σημαντική συμβουλή	Внимание / важный совет
	Disponível / ocupado / OK	Υπάρχει / χρησιμοποιείται / εντάξει	Присутствует / Исправно
	Indisponível/não ocupado / não OK	Δεν υπάρχει / δεν χρησιμοποιείται / δεν είναι εντάξει	Отсутствует / неисправно
	Luz traseira / lâmpada traseira	Οπίσθιο φως / οπίσθιος φανός	Задняя фара
	Luz de Stop	Φανός πέδησης	Стоп-сигнал
	Pisca de viragem à esquerda	Αριστερός δείκτης αλλαγής πορείας (φλας)	Индикатор левого поворотника
	IPiscade viragem à direita	Δεξιός δείκτης αλλαγής πορείας (φλας)	Индикатор правого поворотника
	Luz(es) de nevoeiro traseira(s)	Οπίσθιος(-οι) φανός(-οί) ομίχλης	Задние противотуманные фары
	Luz(es) de marcha-atrás	Φανός(-οί) οπισθοπορείας	Фонари заднего хода
	Ligação à Terra (31)	Γείωση (31)	Заземление (31)
	Standard	Πρότυπο	Стандартное
	Facultativo / opção	Προαιρετικό	Дополнительное / опция
	Interior / a partir do interior	εσωτερικά	внутри / изнутри
	Exterior / a partir do exterior	εξωτερικά	снаружи / снаружи
	Veículo com volante à esquerda	Αριστεροτίμονο όχημα	Автомобиль с левым рулем
	Veículo com volante à direita	Δεξιότιμονο όχημα	Автомобиль с правым рулем
	Binário	Ροπή στρέψης	Крутящий момент
	Quantidade	Ποσότητα	Количество

	ZH	KO	JA
	位置	지점/위치	位置/場所
	运动	이동	移動
	断开	연결 해제 / 분리	切り離し / 取り外し
	连接	연결 / 부착	接続 / 取り付け
	车辆左侧和右侧	차의 왼쪽/오른쪽	車両の左右側面
	检查 / 运行该功能 测试	확인 / 기능 검사 실시	機能の確認 / 実施 試験
	查看车间工作手册	정비소 매뉴얼 확인	ワークショップマニュアルを参照
	注意 / 重要建议	주의/중요 알림	注意 / 重要な勧告
	存在 / 占用 / 正常	있음 / 점유 / 정상	使用 / 使用中 / OK
	不存在 / 未占用 / 不正常	없음 / 비점유 / 비정상	不使用 / 使用中でない / OKでない
	尾灯	미등 / 테일 램프	テールライト / テールランプ
	停车灯	정지등	ストップライト
	左转弯指示灯	좌회전 지시등	左折方向指示器
	右转弯指示灯	우회전 지시등	右折方向指示器
	后雾灯	후면 안개등	後部フォグランプ
	倒车灯	후진등	後退灯
	接地装置(31)	접지(31)	接地またはアース (31)
	标准	표준	標準
	可选/选项	선택 / 옵션	任意の / オプション
	内部/来自内部	내부 / 내부에서	内側 / 内側から
	外部/来自外部	외부 / 외부에서	外側 / 外側から
	左侧驾驶车辆	운전석이 왼쪽인 차	左ハンドル車
	右侧驾驶车辆	운전석이 오른쪽인 차	右ハンドル車
	转矩	토크	トルク
	数量	수량	量

	SA	IT	TR
	الموقع/المكان	Posizione/Località	Pozisyon/Konum
	الحركة	Movimento	Hareket
	قم بالقطع / الفصل	Disconnettere / scollegare	Bağlantıyı kes/çıkart
	قم بالتوصيل / الربط	Connettere / collegare	Bağla/tak
	الجانب الأيسر والأيمن من المركبة	Lato sinistro e destro del veicolo	Aracın sol ve sağ tarafı
	الاختبار الوظيفي، قم بالتحقق من / إجراء	Controllare / eseguire la prova funzionale	Kontrol et/işlev testini gerçekleştir
	راجع كتيب ورشة العمل	Vedere il manuale di officina	Atölye el kitabına bak
	برجاء الانتباه / نصيحة مهمة	Attenzione / avvertenza importante	Dikkat/önemli öneri
	موجود / مشغول / موافق	Presente / occupato / OK	Mevcut/meşgul/tamam
	غير موجود / غير مشغول / غير موافق	Non presente / non occupato / non OK	Mevcut değil/meşgul değil/ tamam değil
	الضوء الخلفي / مصباح الإنارة الخلفية	Luce posteriore / fanale posteriore	Arka ışık/arka lamba
	إيقاف الضوء	Luce di stop	Fren lambası
	مؤشر إشارة الانعطاف لليسر	Indicatore di svolta a sinistra	Sola dönüş sinyal göstergesi
	مؤشر إشارة الانعطاف لليسر	Indicatore di svolta a destra	Sağa dönüş sinyal göstergesi
	مصباح (مصابيح) الضباب الخلفي	Luce(i) fendinebbia posteriore	Arka sis lambası/lambaları
	أضواء الرجوع إلي الوراء	Luce(i) retromarcia	Geri vites lambası/lambaları
	الأرض أو التربة (٣١)	Terra (31)	Zemin veya Toprak (31)
	معياري أساسي	Standard	Standart
	اختياري / الخيار	Opzionale / opzione	İsteğe bağlı/seçenek
	داخلي / من الداخل	dentro / dall'interno	iç/içten
	خارجي / من الخارج	fuori / dall'esterno	dış/dıştan
	مركبة بقيادة من الجهة اليسرى	Veicolo con guida a sinistra	Sol direksiyonlu araç
	مركبة بقيادة من الجهة اليمنى	Veicolo con guida a destra	Sağ direksiyonlu araç
	عزم الدوران	Coppia	Tork
	الكمية	Quantità	Miktar

	BK	WH	GY	GN	RD	BU	YE	BN	VT	OG
EN	black	white	grey	green	red	blue	yellow	brown	purple	orange
ES	negro	blanco	gris	verde	rojo	azul	amarillo	marrón	violeta	naranja
FR	noir	blanc	gris	vert	rouge	bleu	jaune	brun	violet	orange
DE	schwarz	weiß	grau	grün	rot	blau	gelb	braun	violett	orange
PT	preto	branco	cinzento	verde	vermelho	azul	amarelo	castanho	violeta	laranja
GR	μαύρο	λευκό	γκρι	πράσινο	κόκκινο	μπλε	κίτρινο	καφέ	μωβ	πορτοκαλί
RU	черный	белый	серый	зеленый	красный	синий	желтый	коричневый	фиолетовый	оранжевый
ZH	黑色	白色	灰色	绿色	红色	蓝色	黄色	棕色	紫色	橙色
KO	블랙	화이트	그레이	그린	레드	블루	옐로	브라운	퍼플	오렌지
JA	黒	白	グレー	緑	赤	青	黄色	茶色	紫	オレンジ
SA	أسود	أبيض	رمادي	أخضر	أحمر	أزرق	أصفر	بني	أرجواني	برتقالي
IT	nero	bianco	grigio	verde	rosso	blu	giallo	marrone	viola	arancione
TR	siyah	beyaz	gri	yeşil	kırmızı	mavi	sarı	kahverengi	mor	turuncu

i

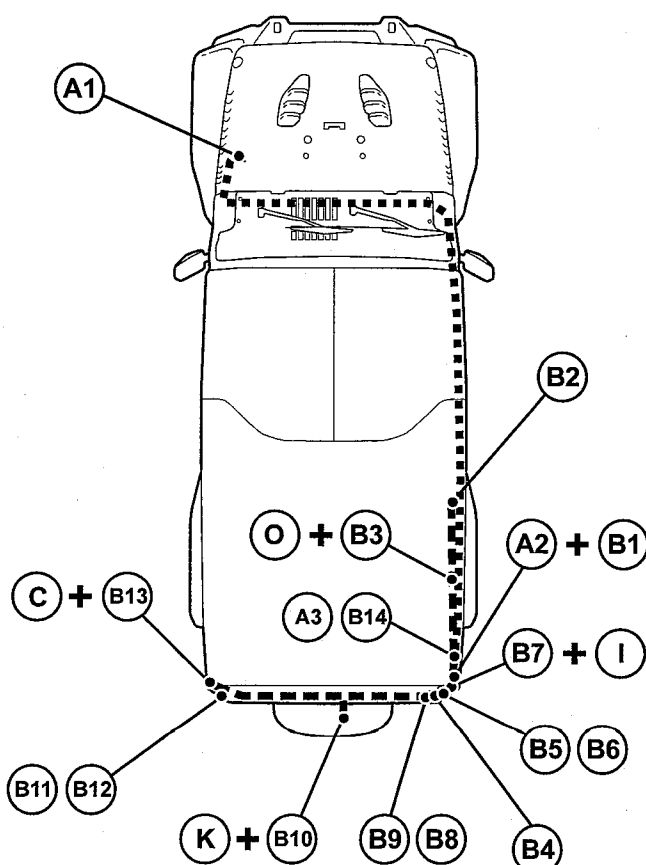
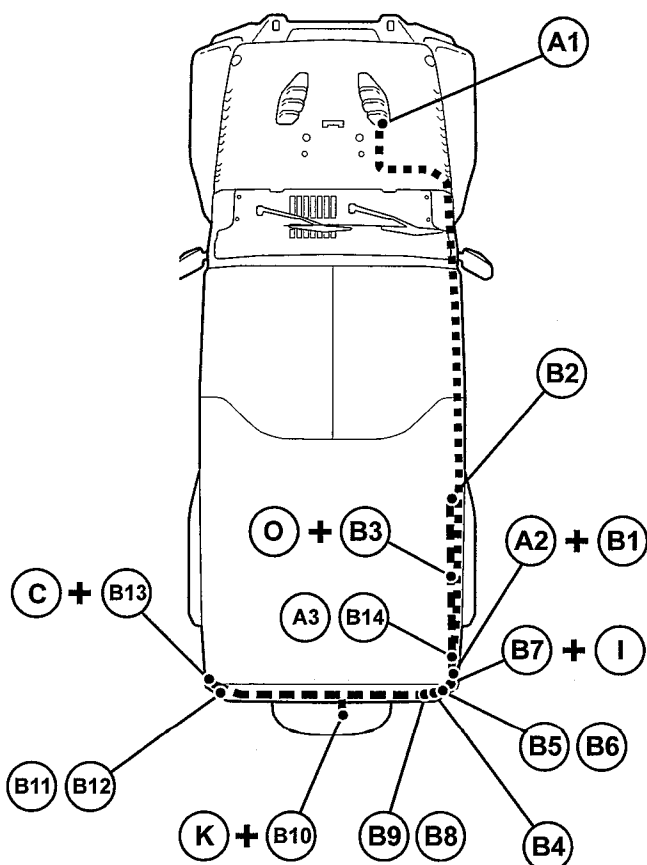
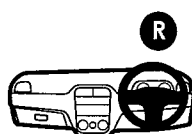
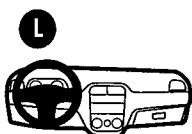

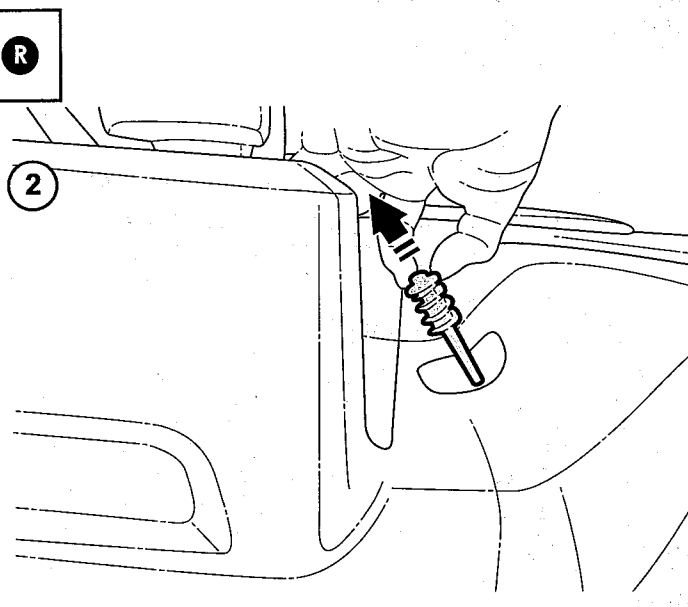
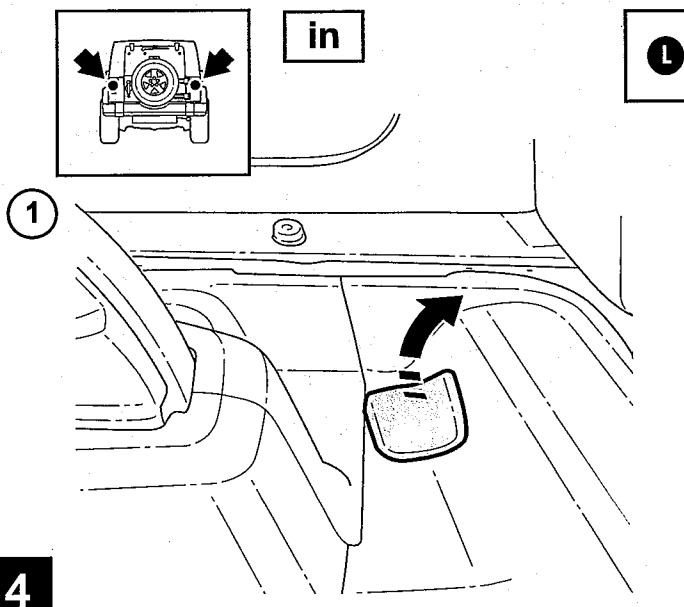
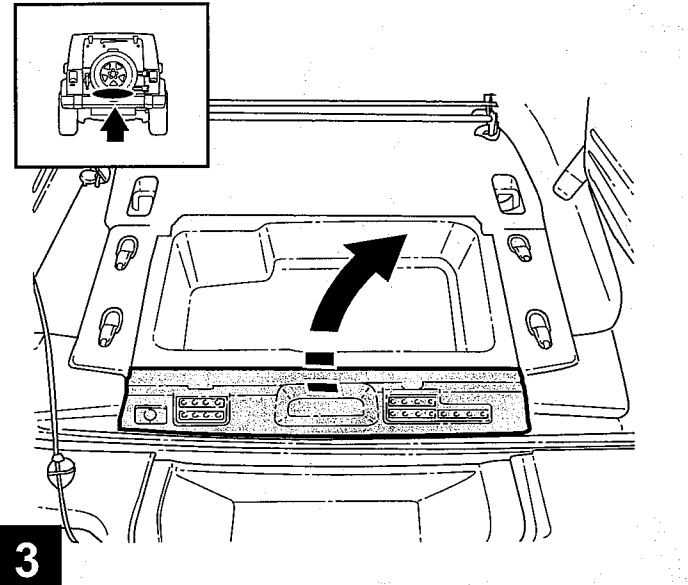
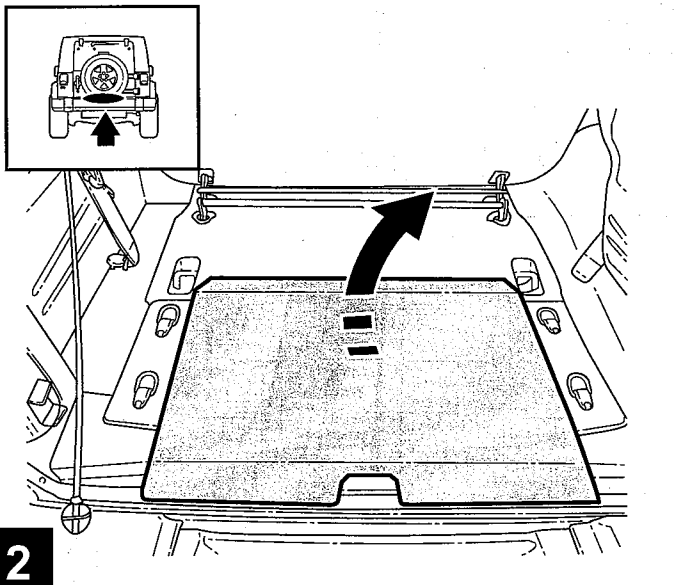
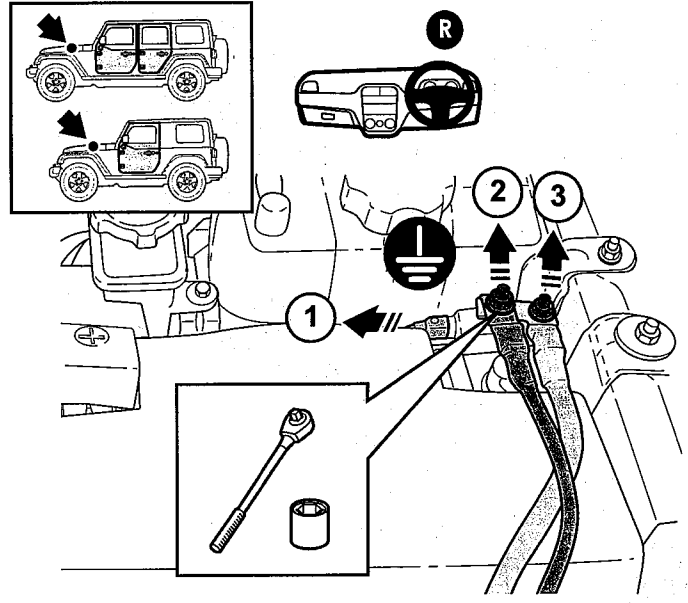
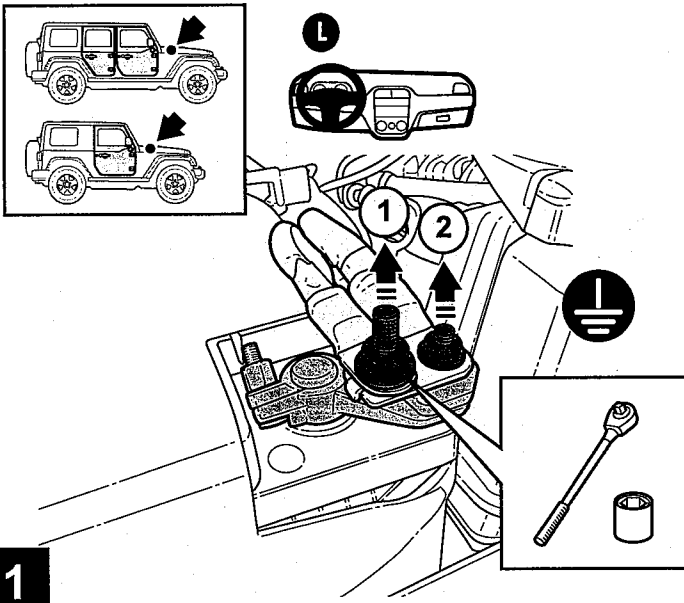

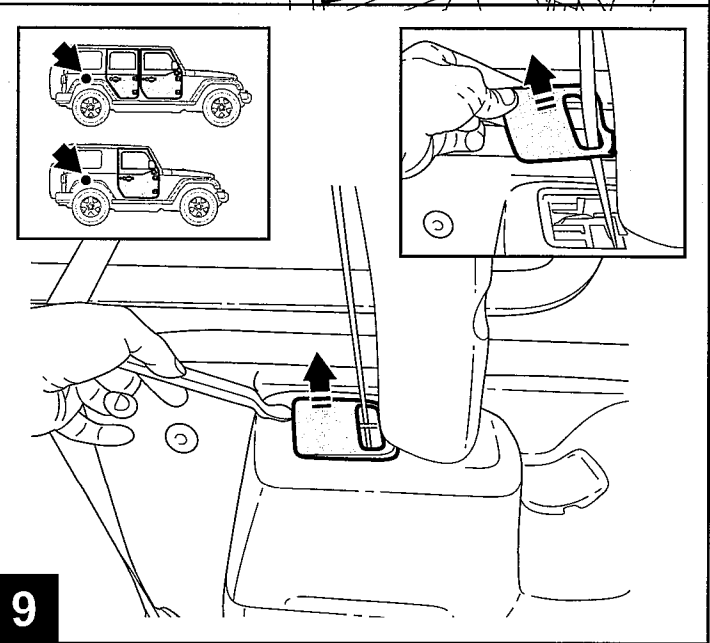
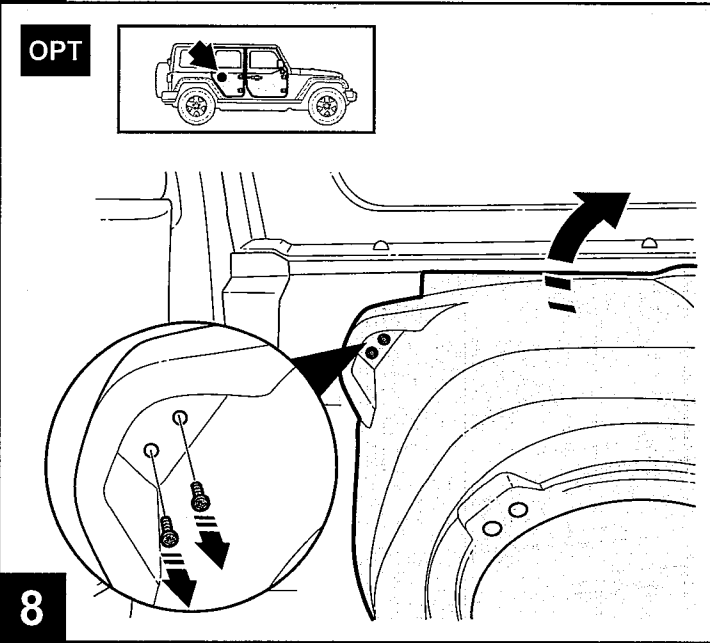
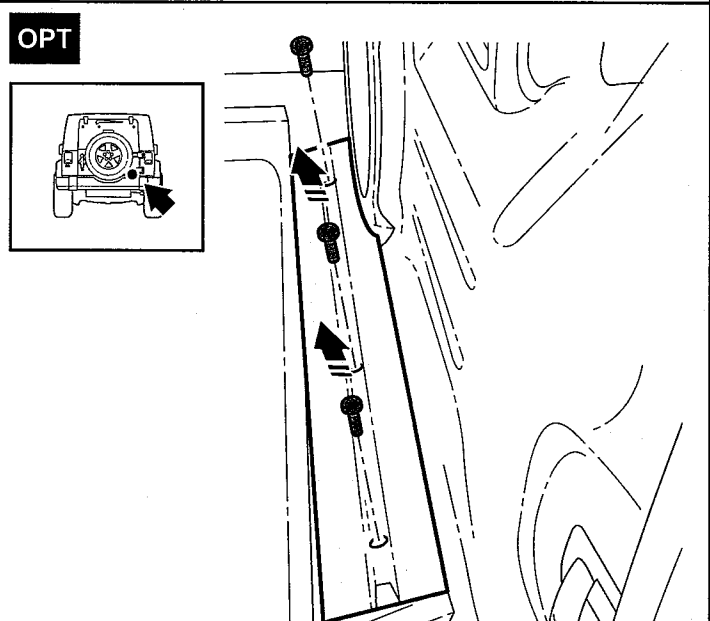
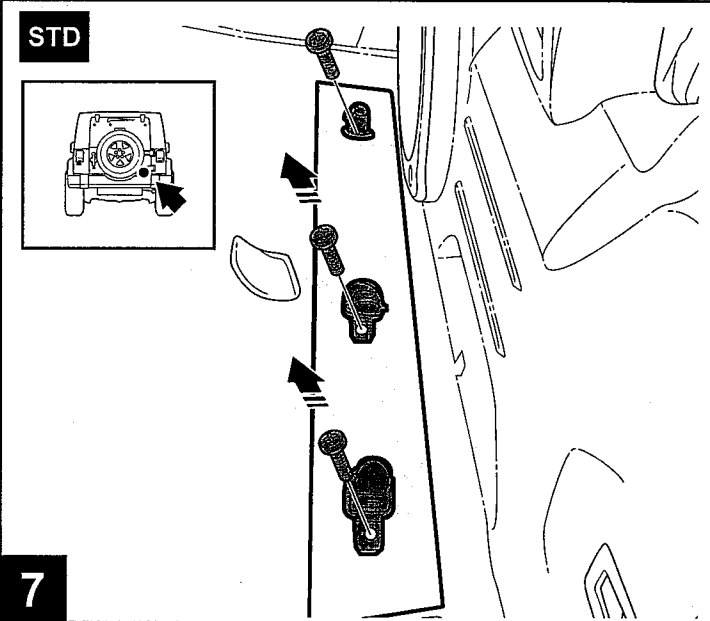
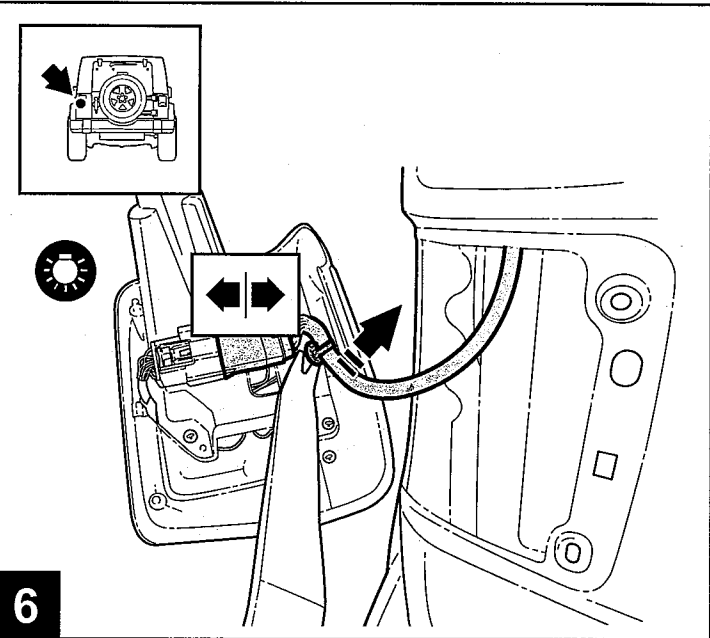
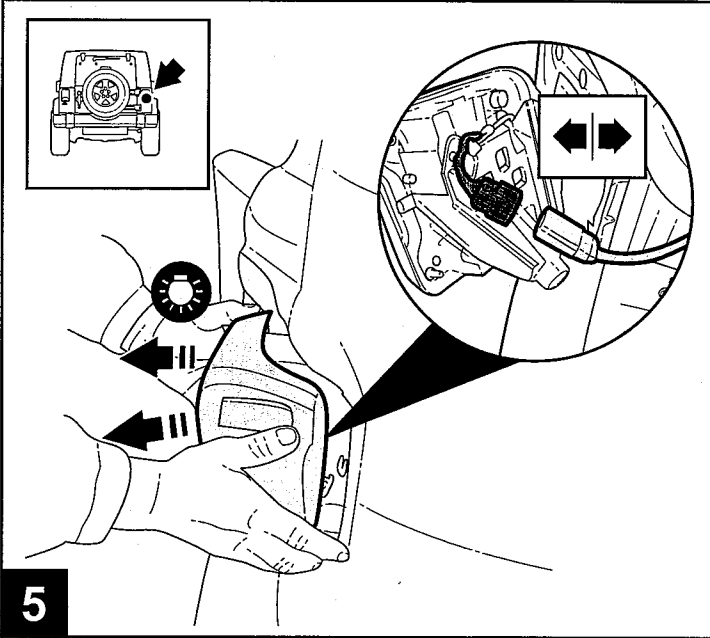

STD

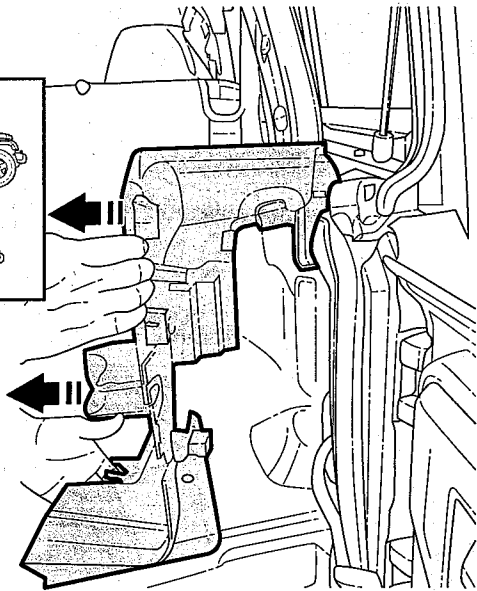
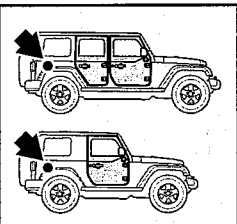

10

OPT

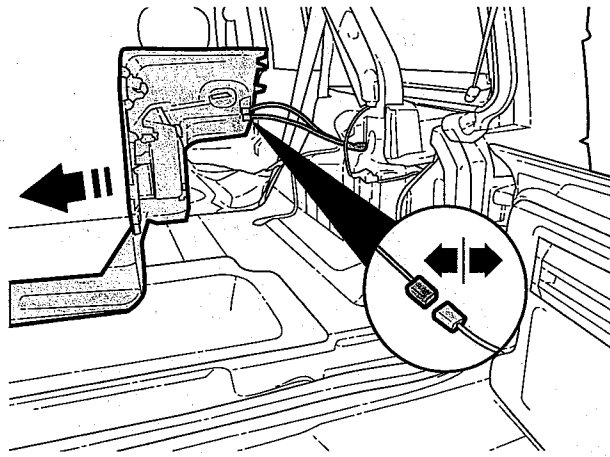
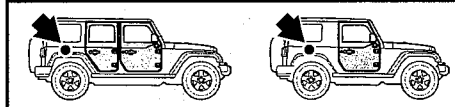

11

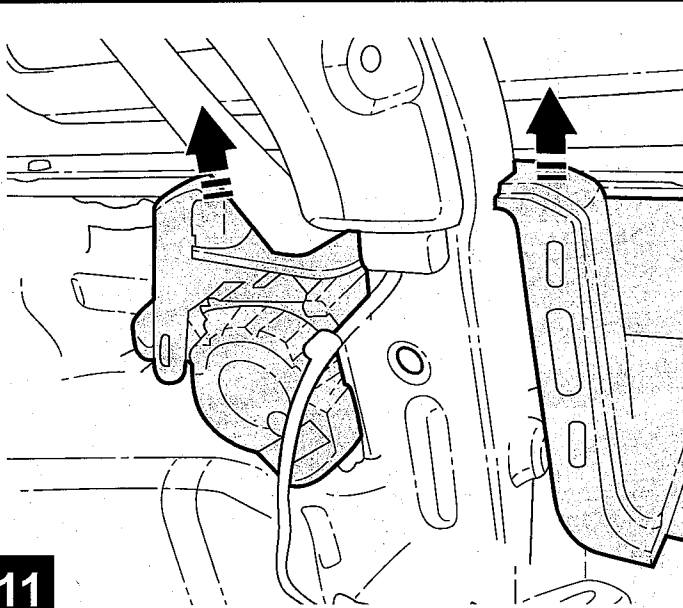

12

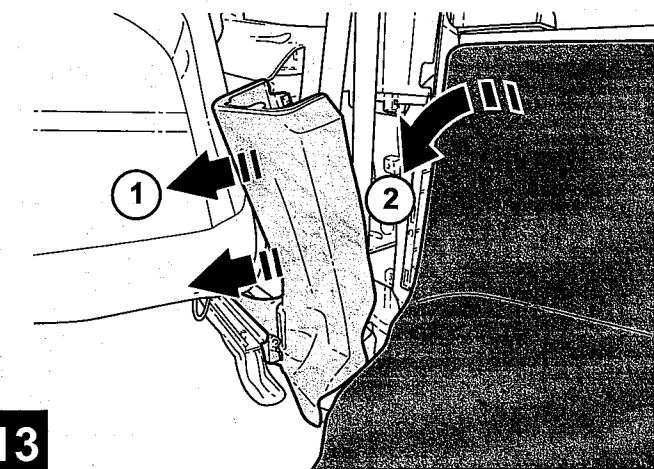
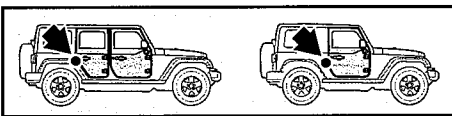
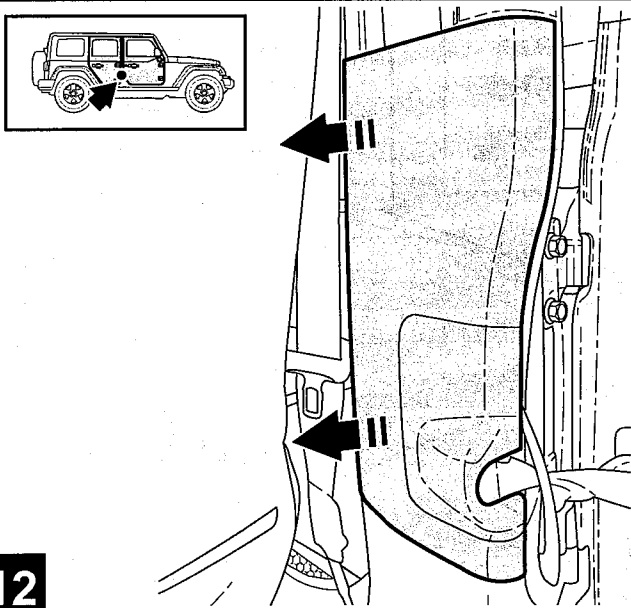

13

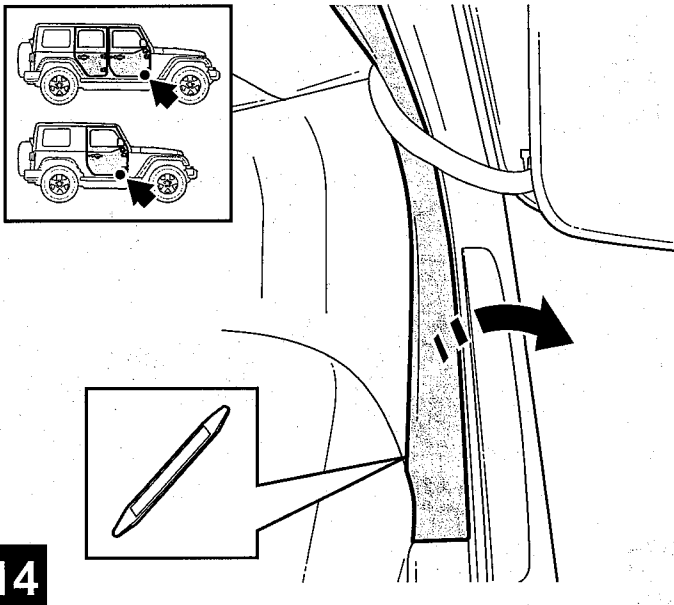

14

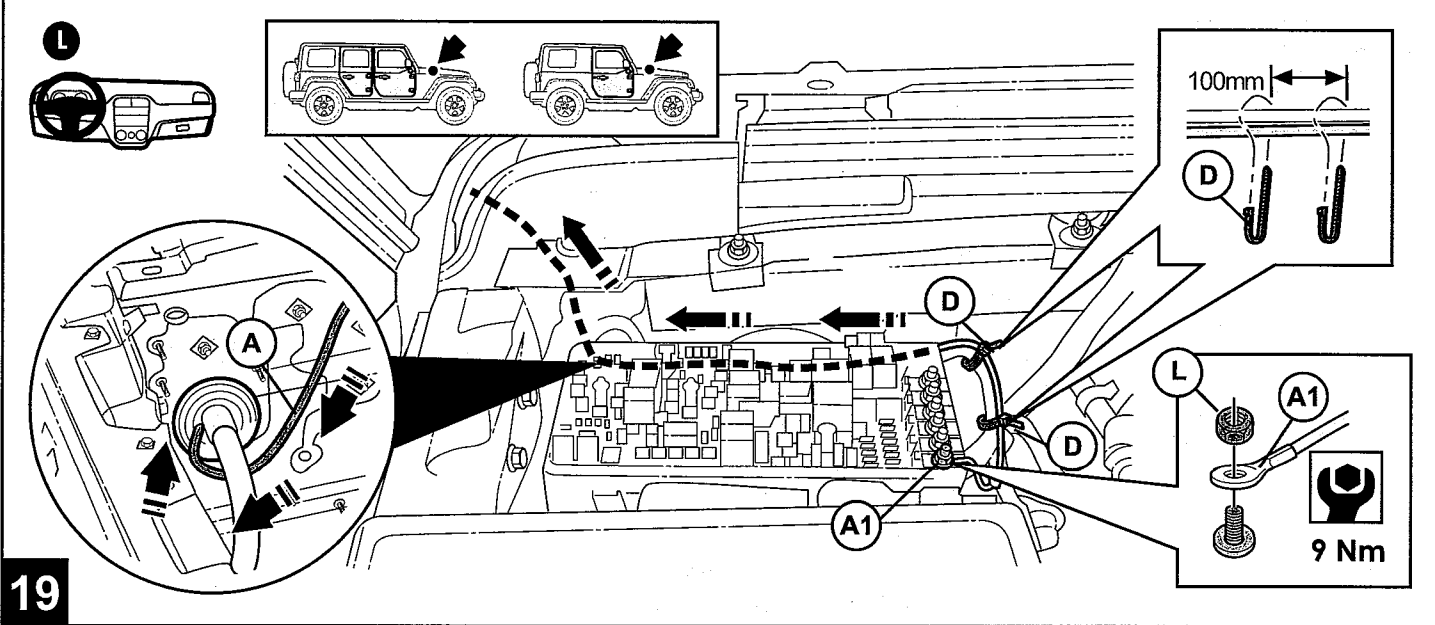
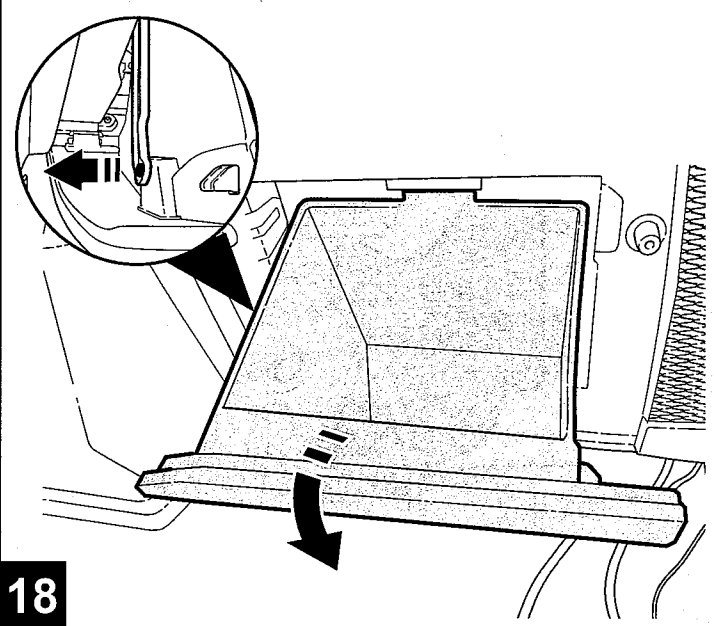
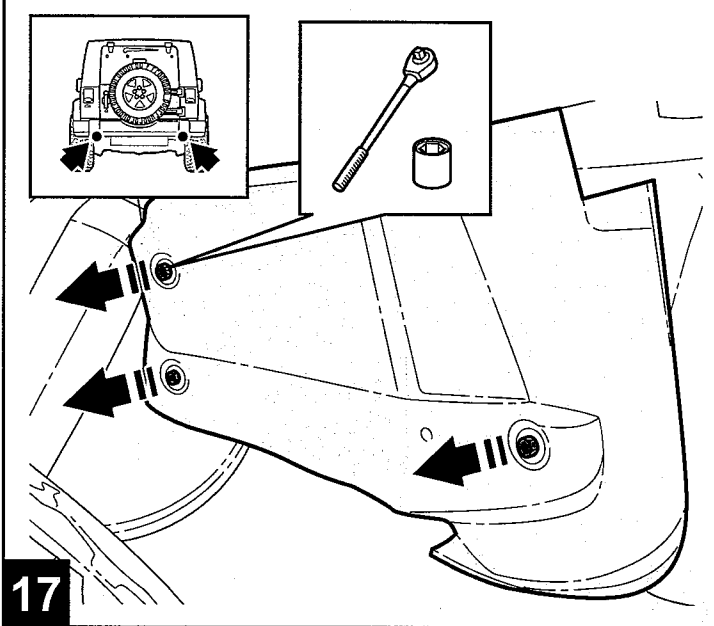
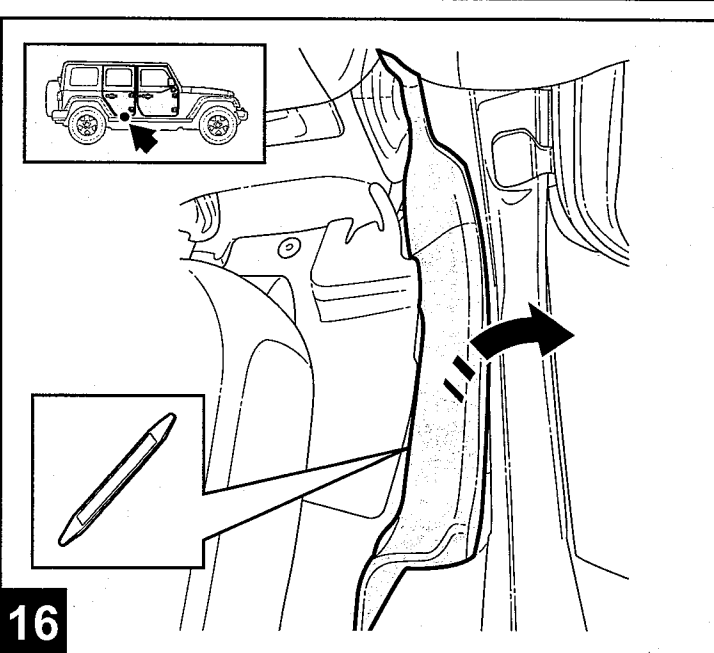
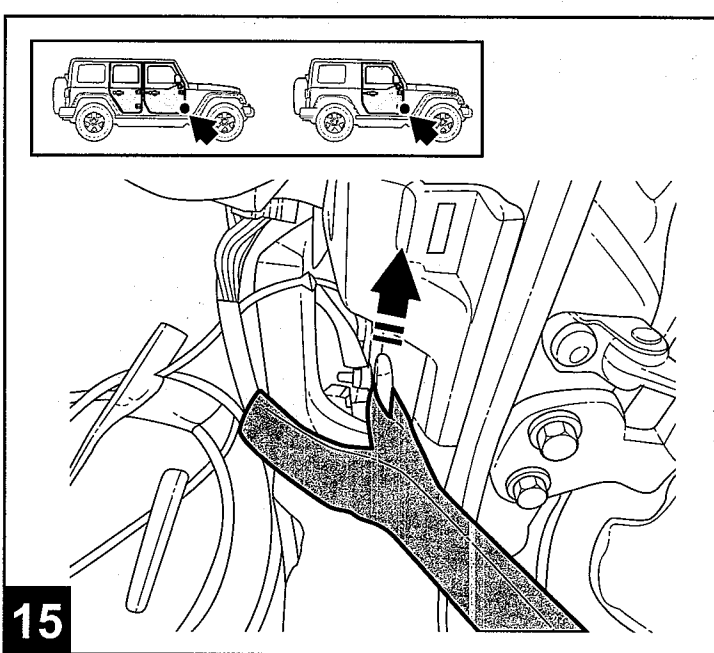

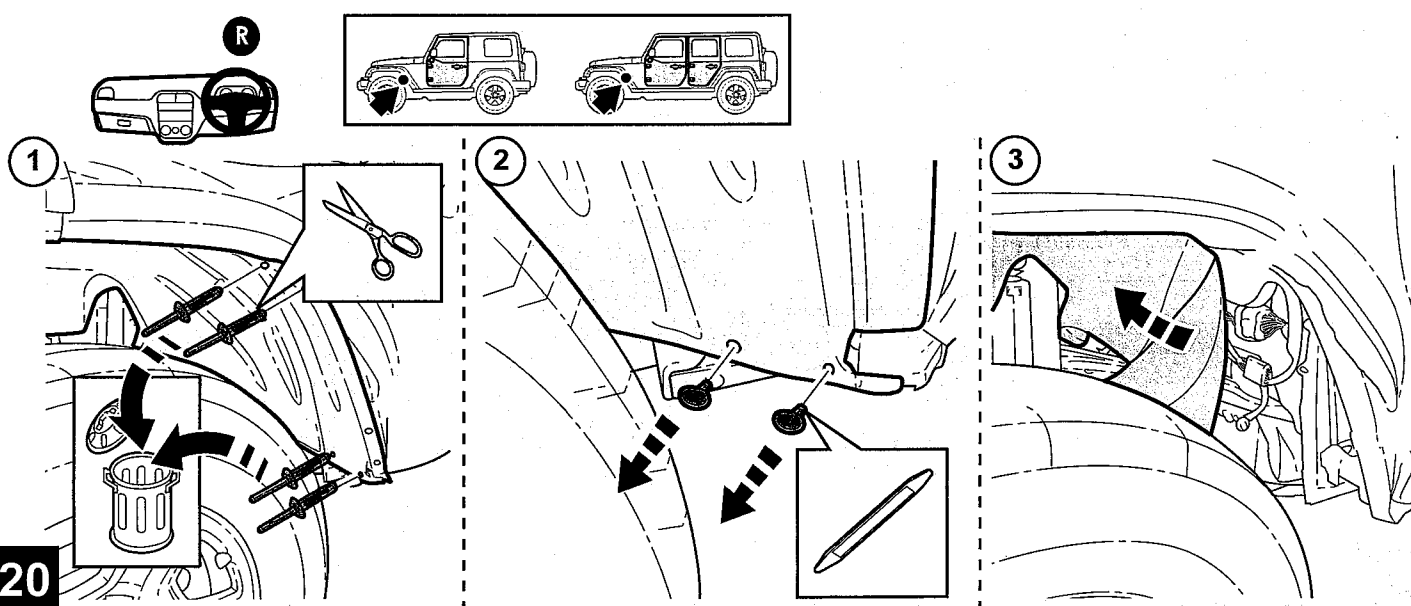
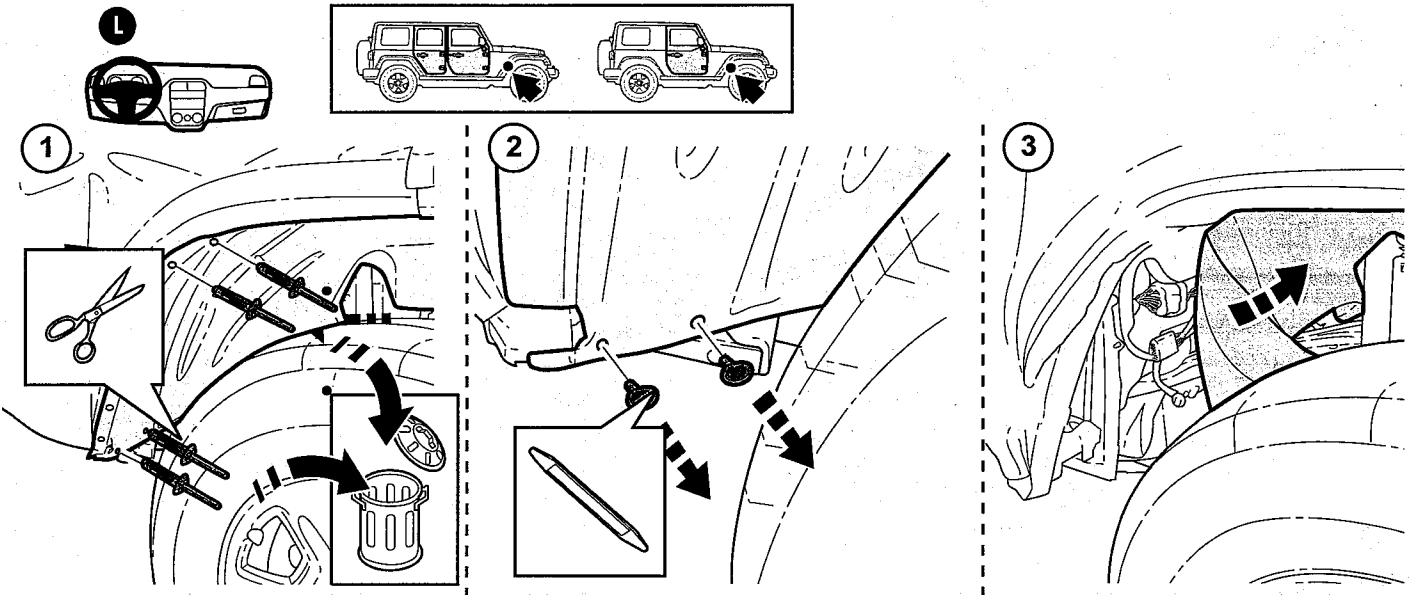
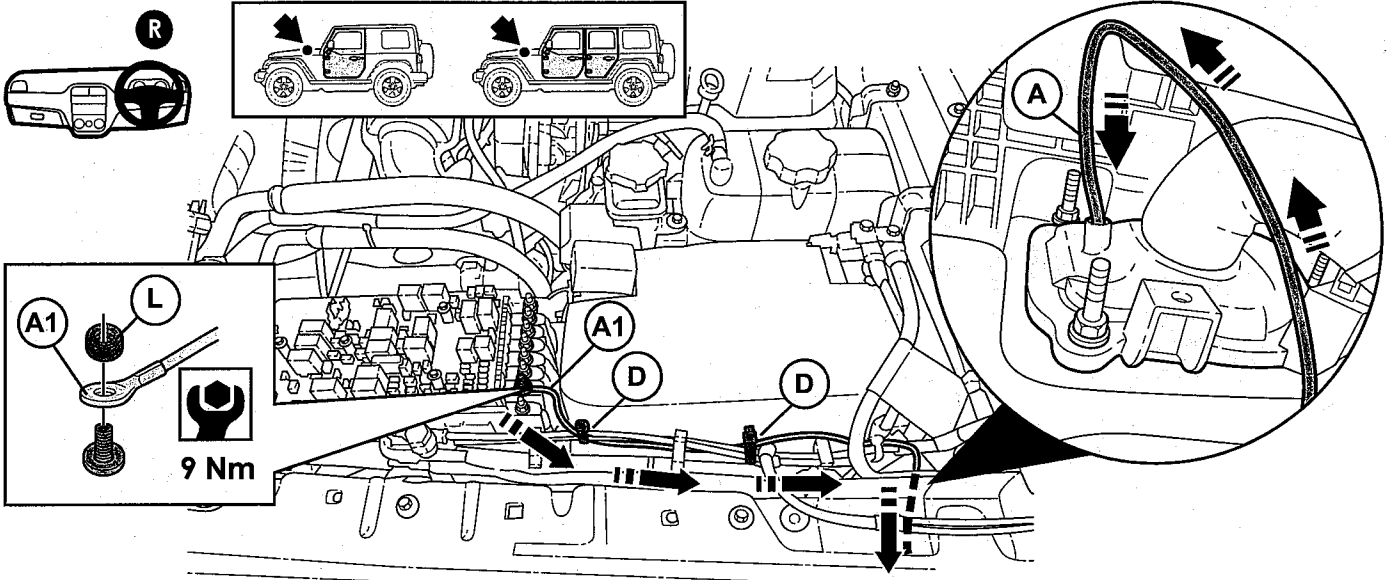

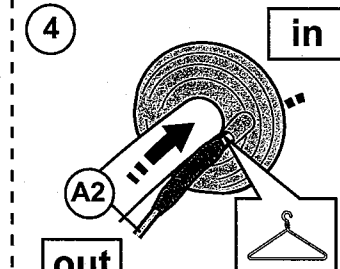
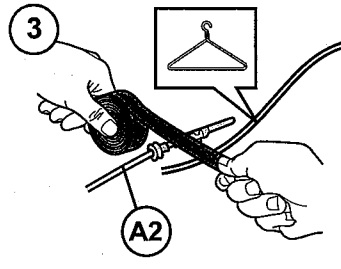
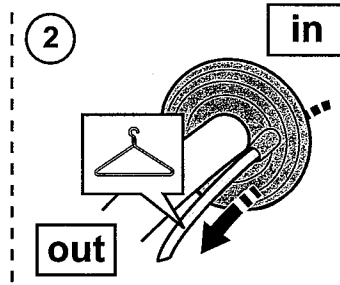
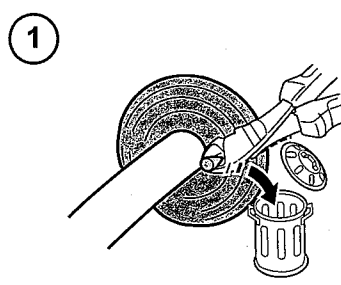
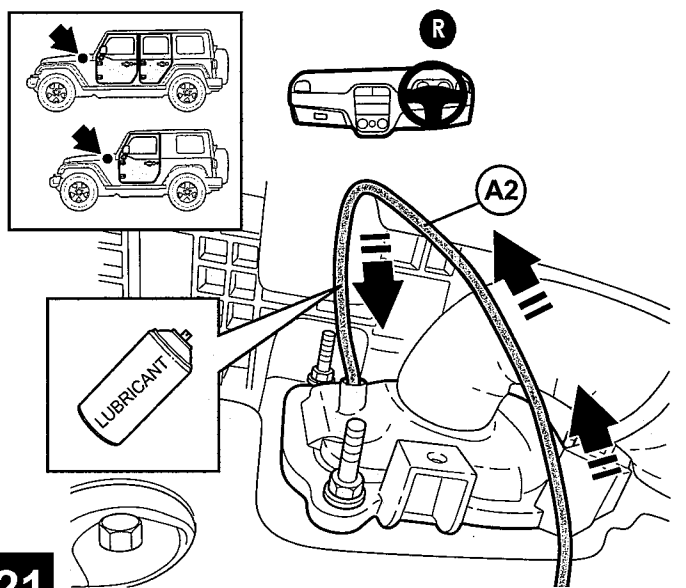
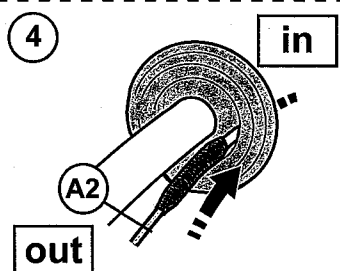
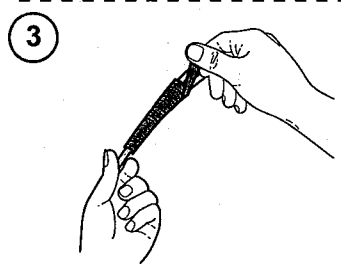
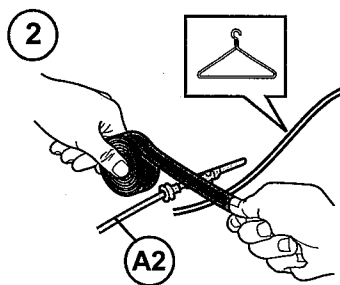
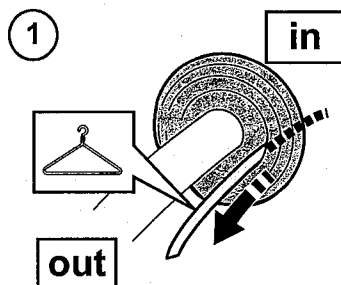
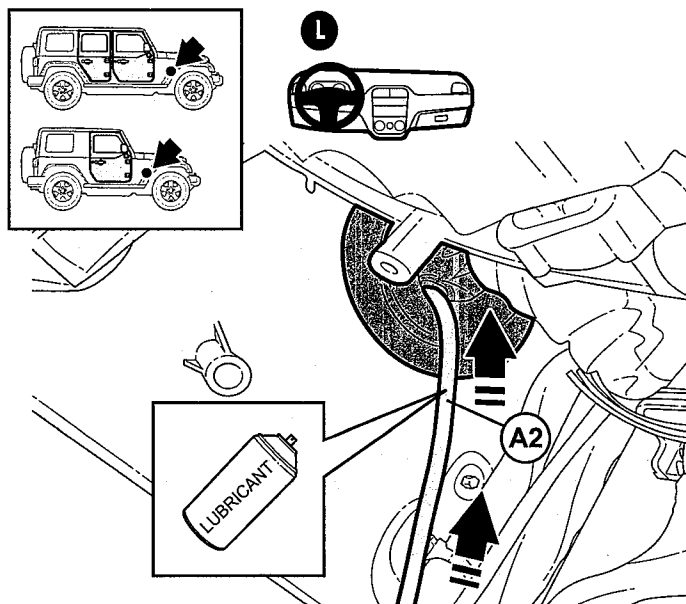

21

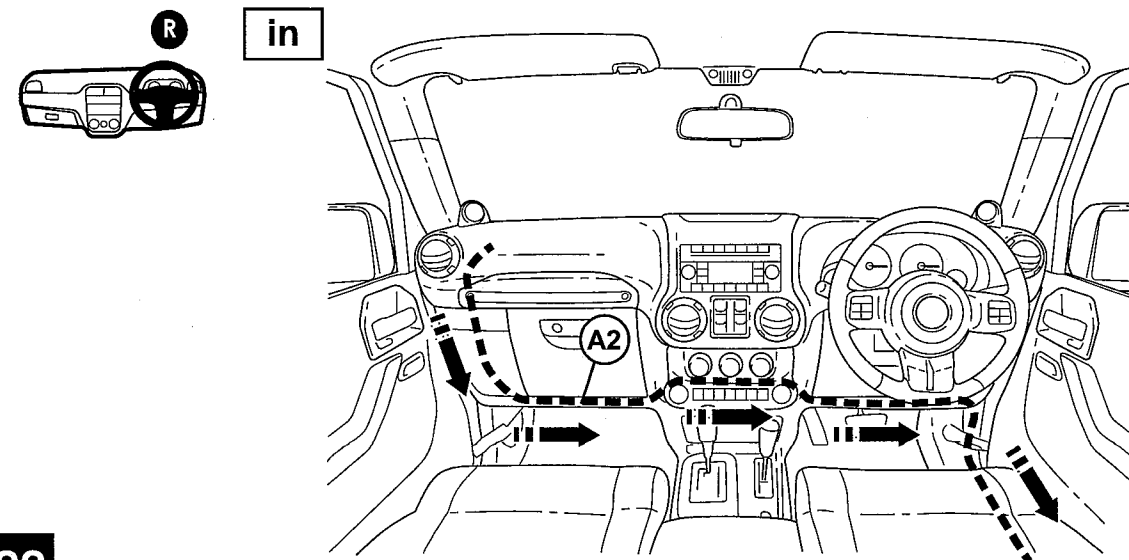

22

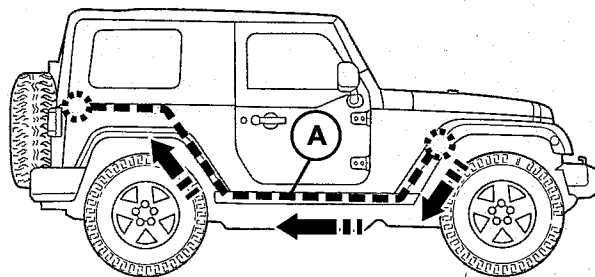
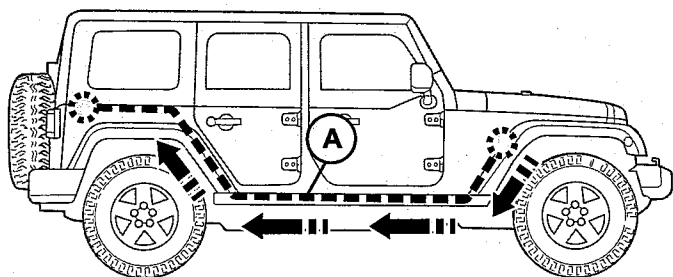

23

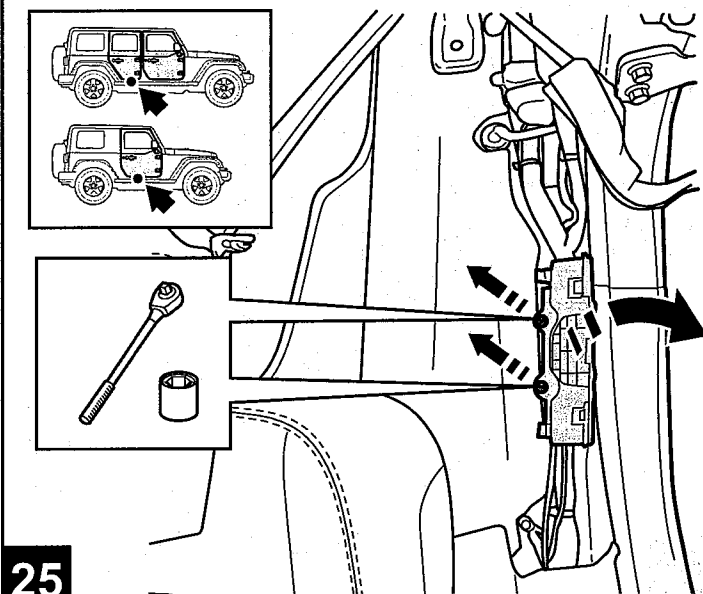
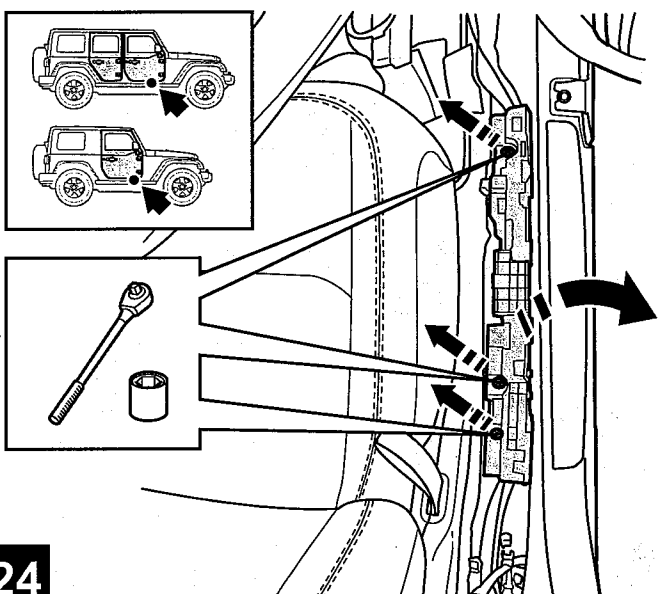

24

25

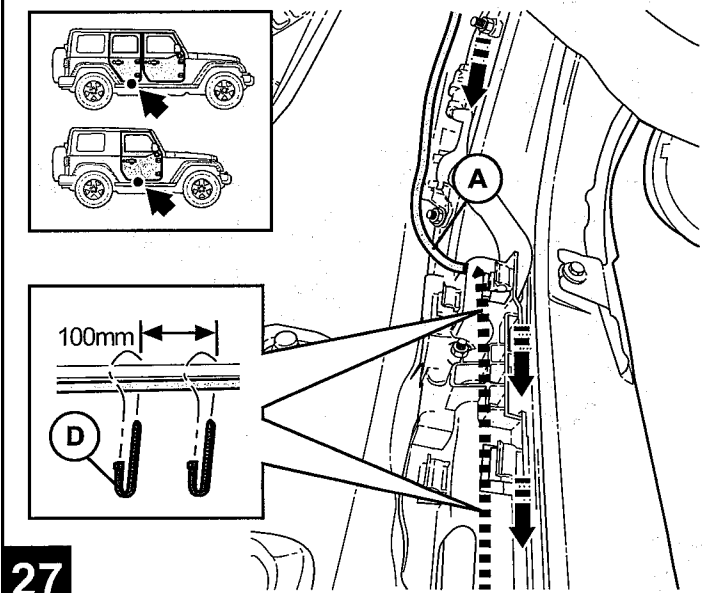
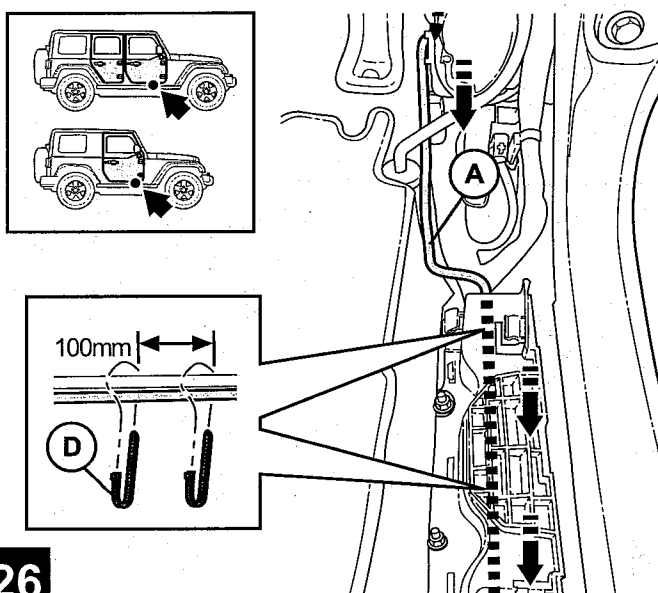

26

27

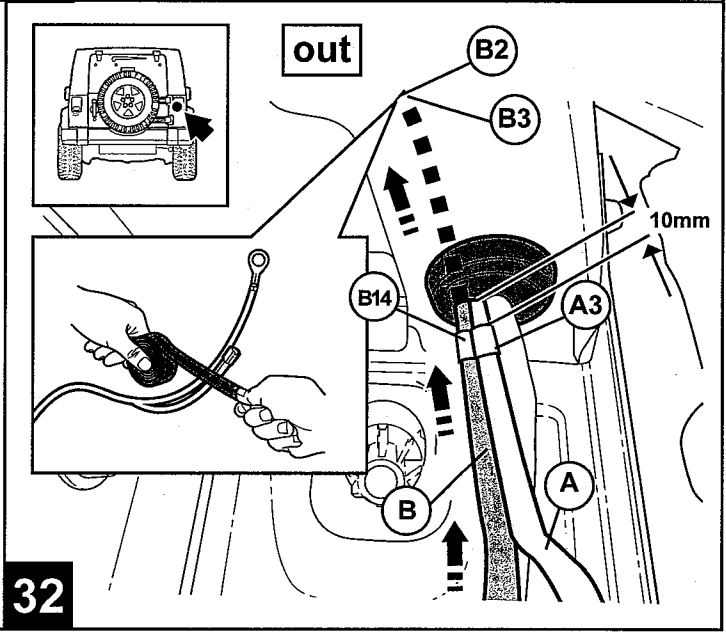
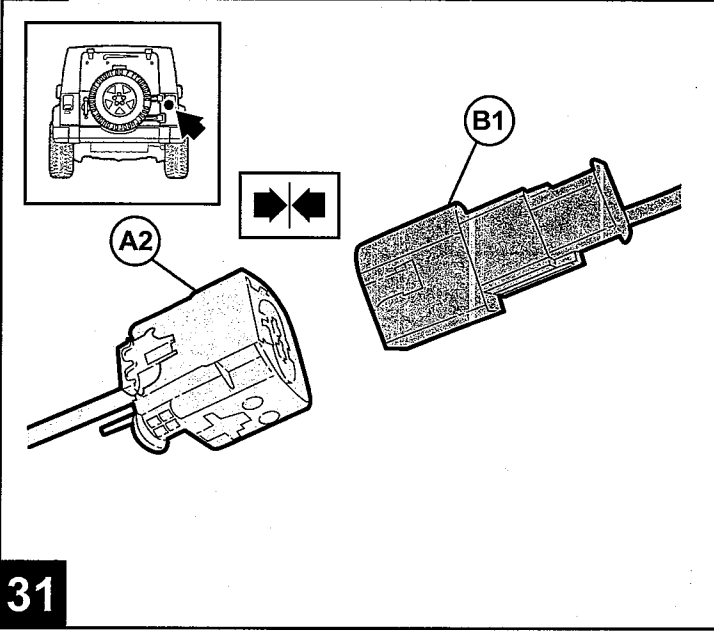
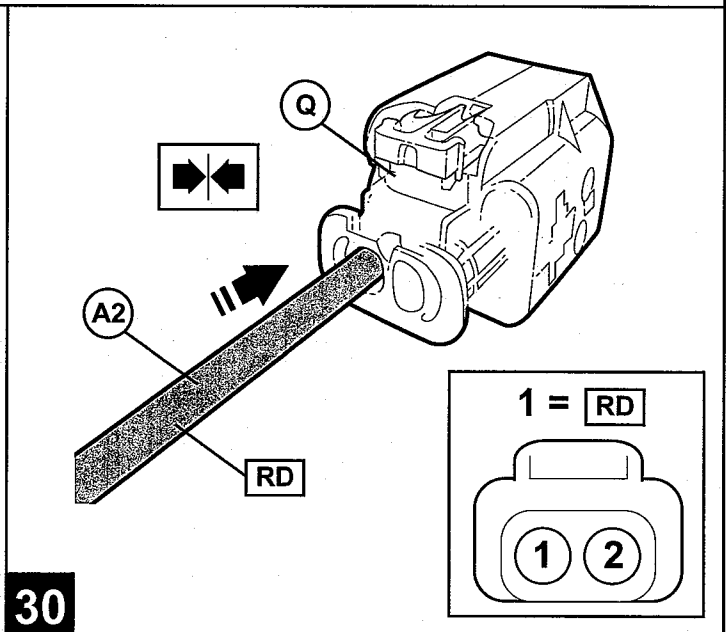
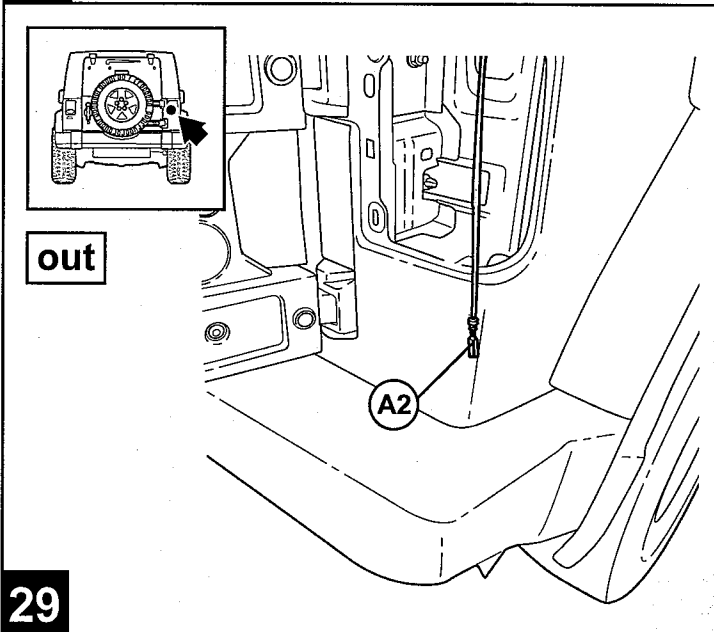
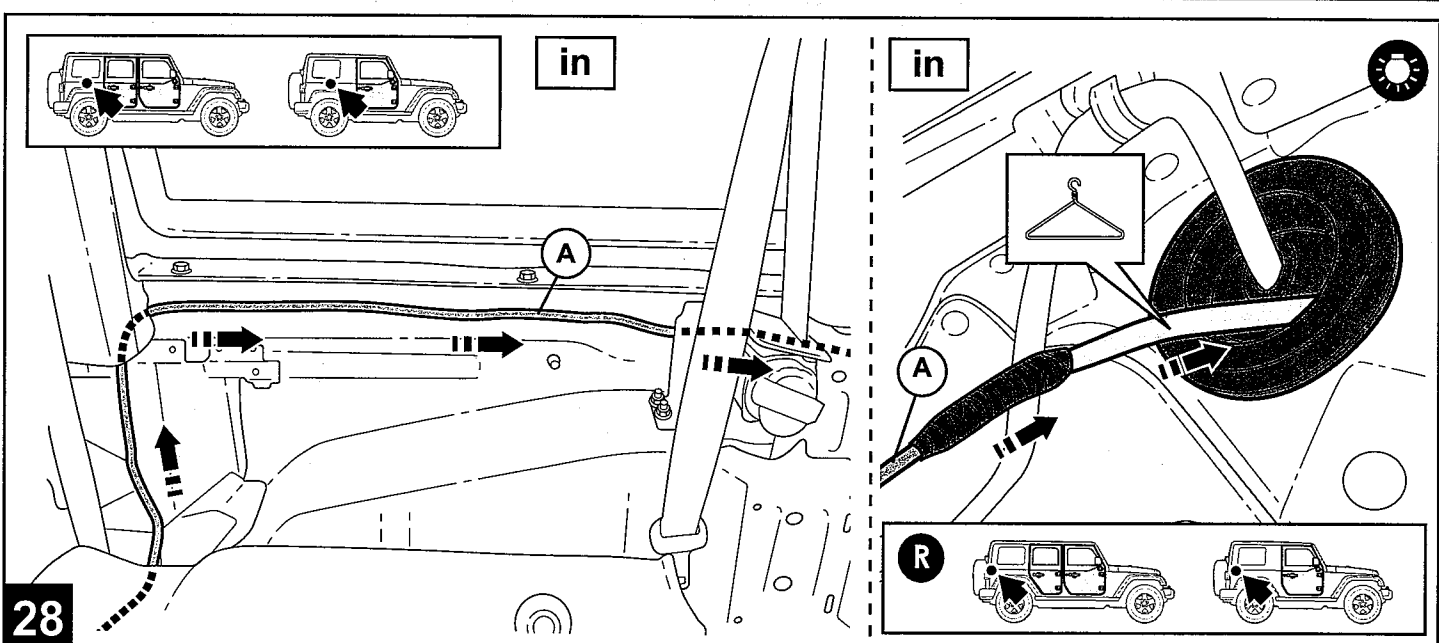

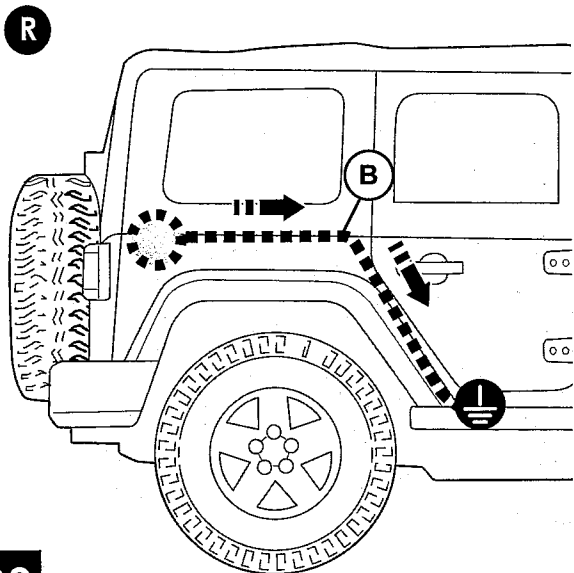

33

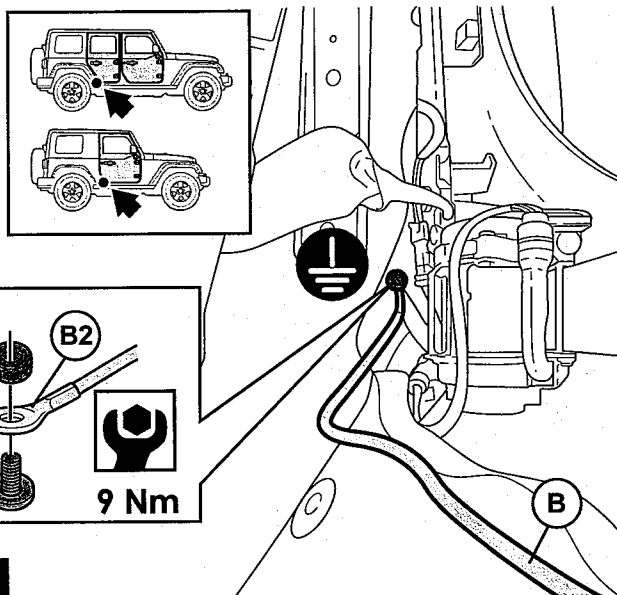

34

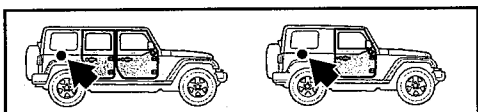

in

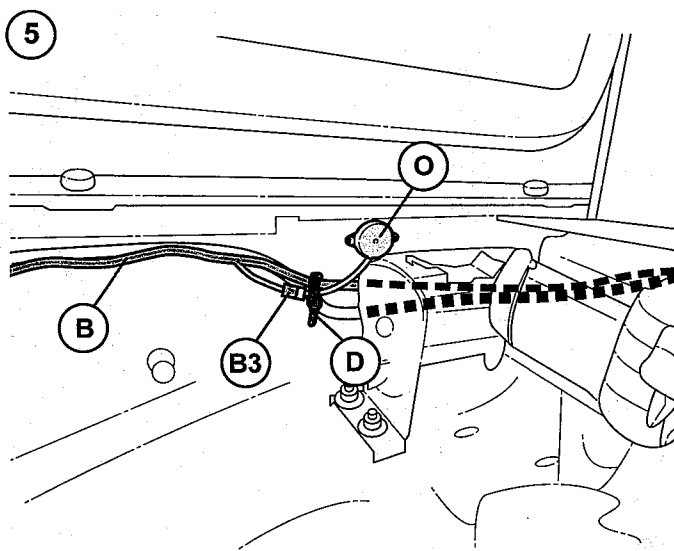

5

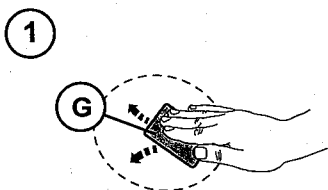

1

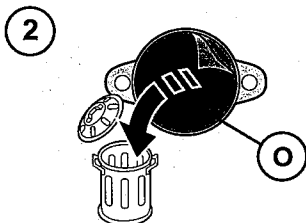

2

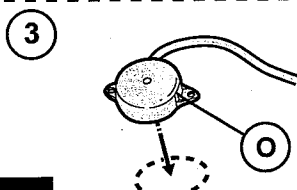

3

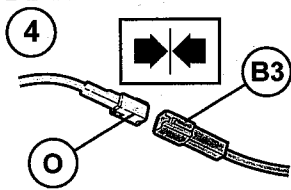

4

35

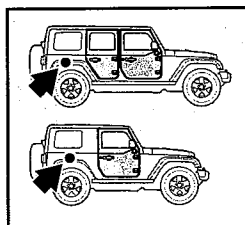

in

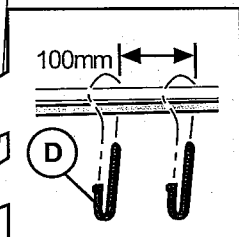

100mm

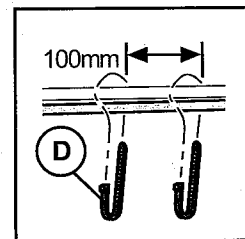

100mm

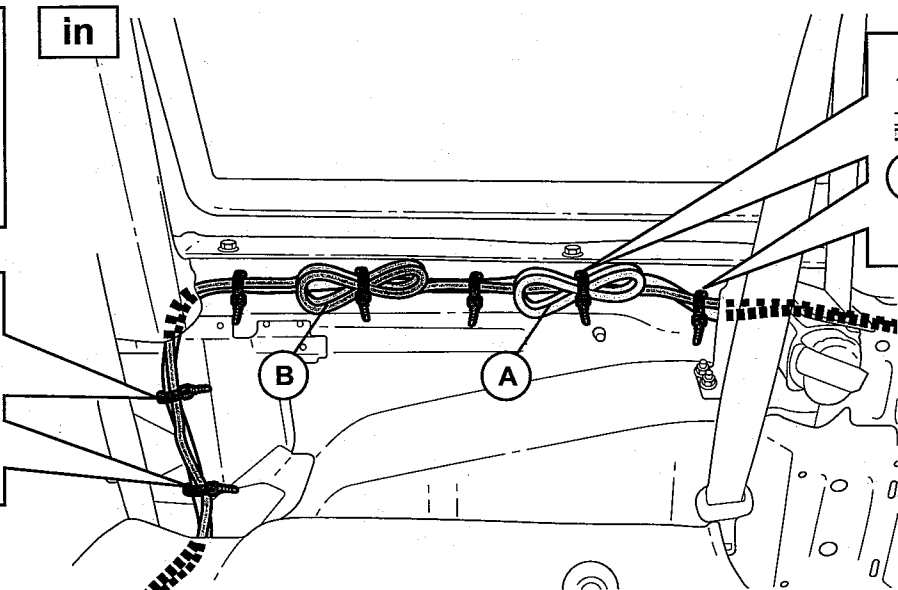

36

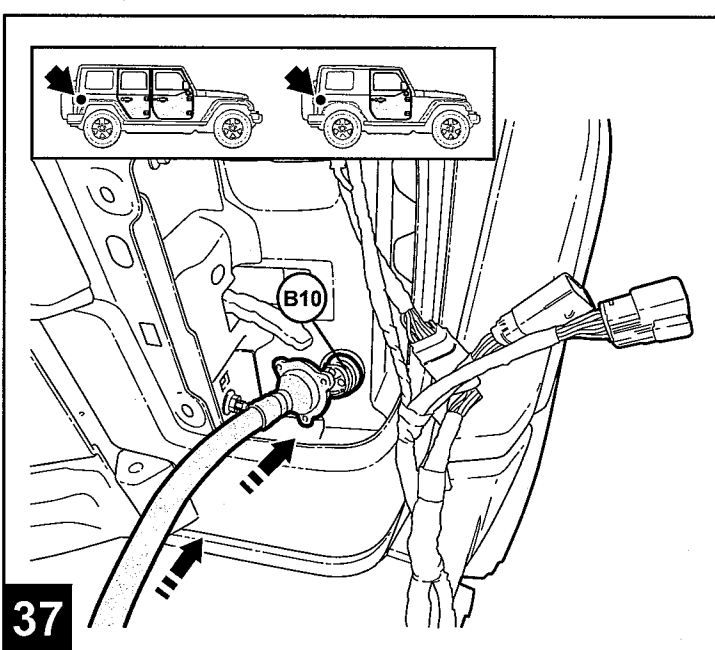

37

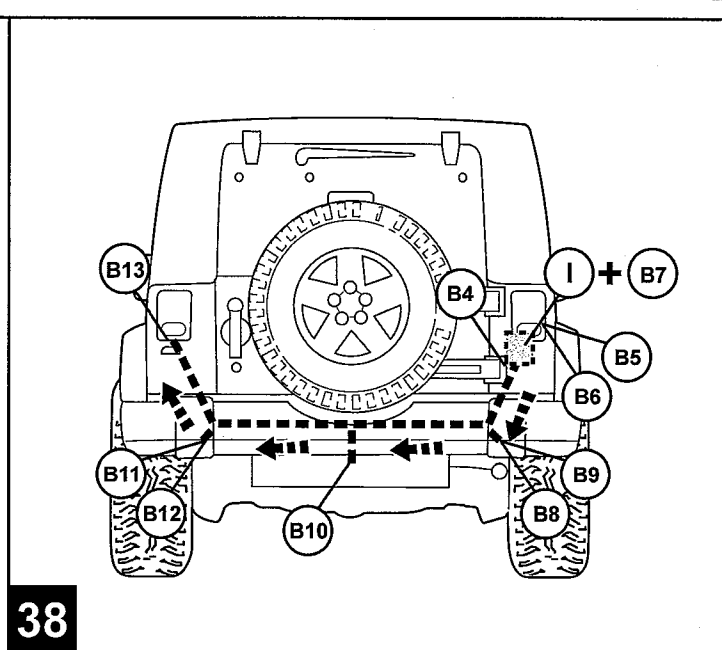

38

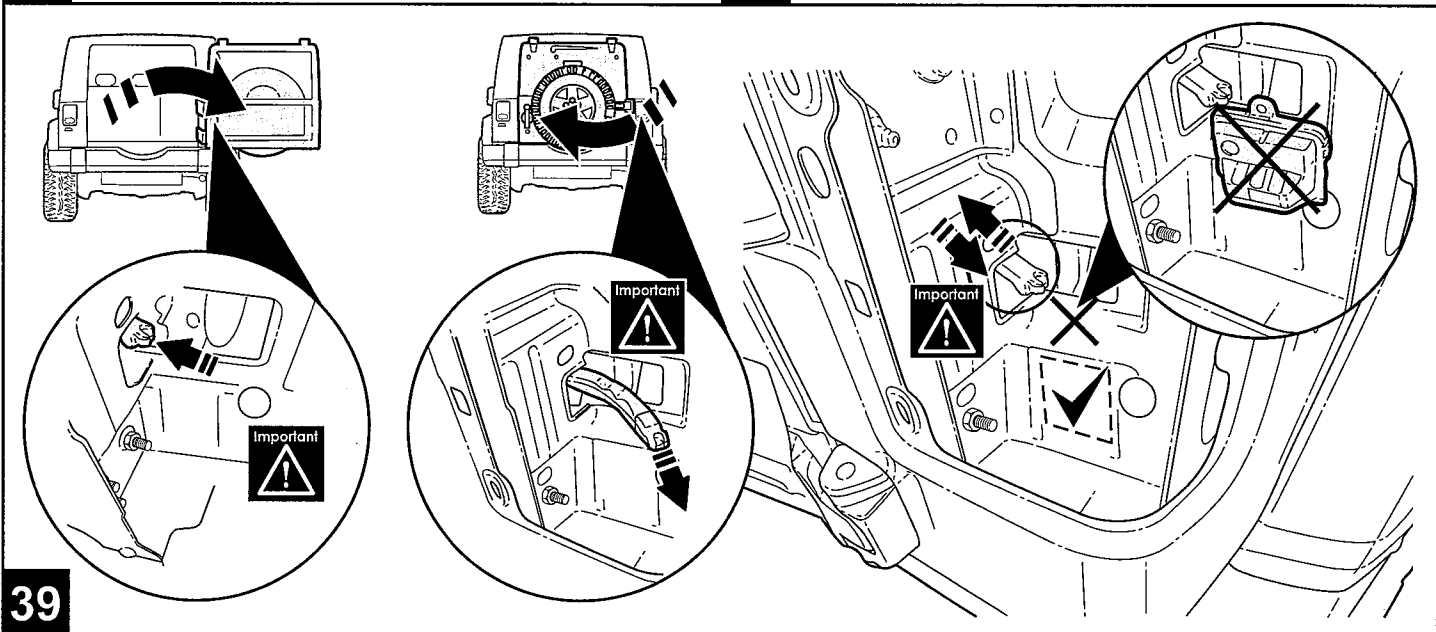

39

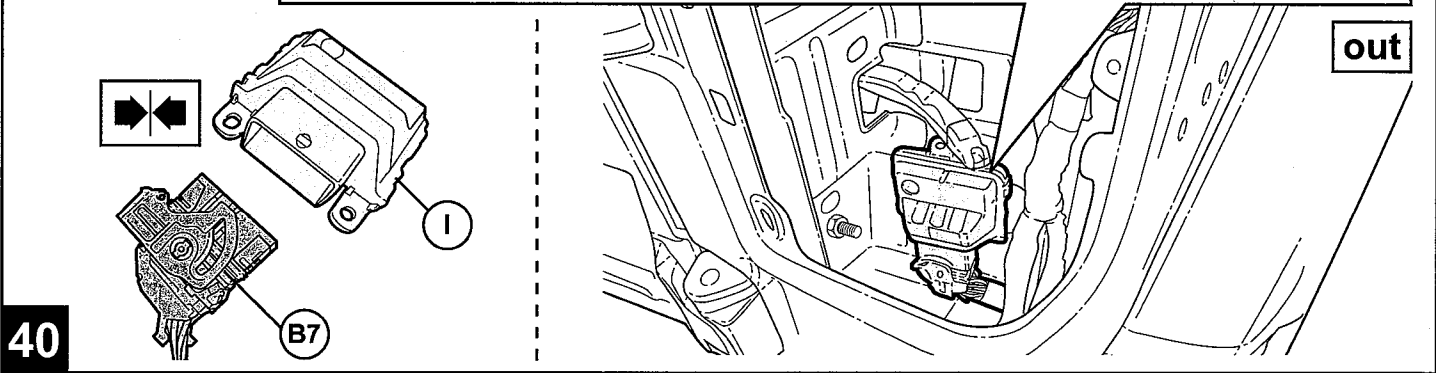
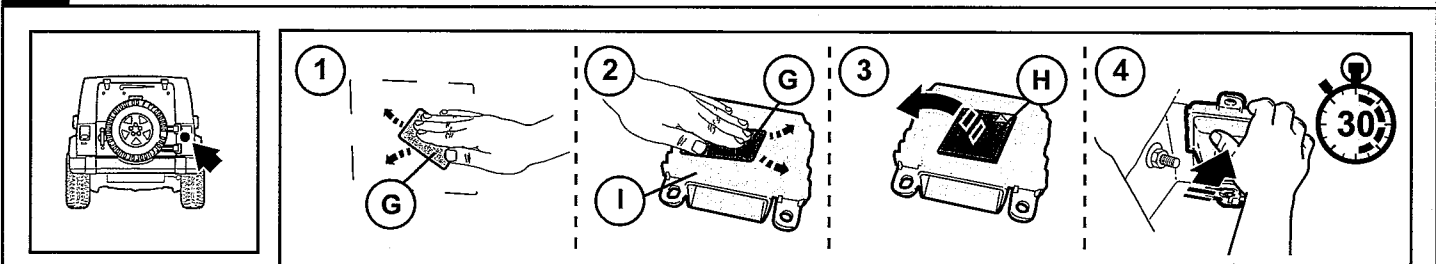

40

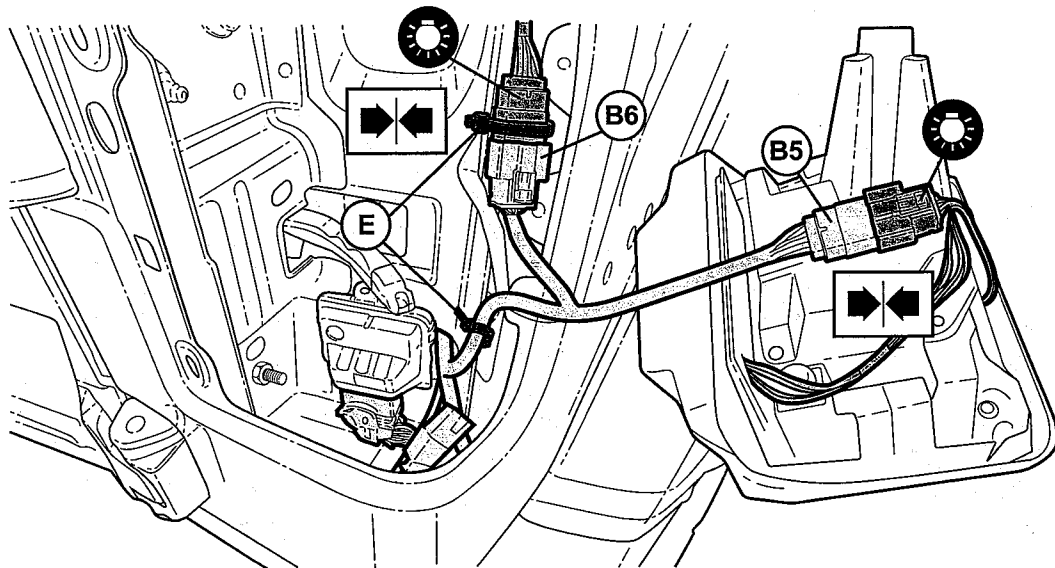
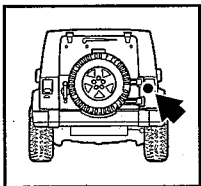

41

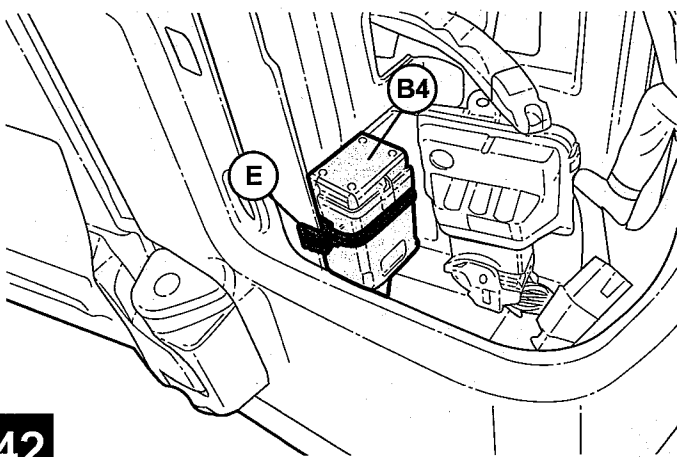
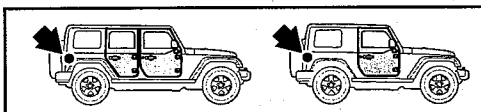

42

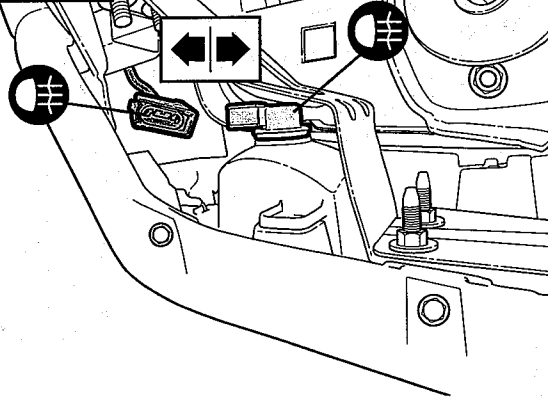
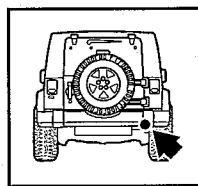

43

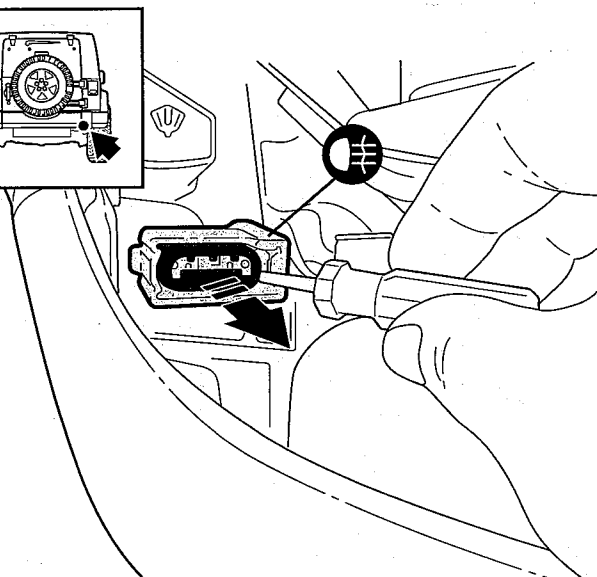
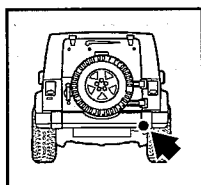

44

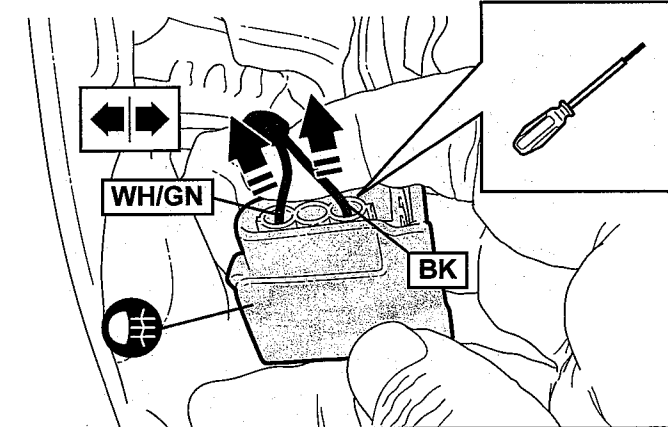

3 = WH/GN 1 = BK

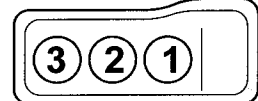

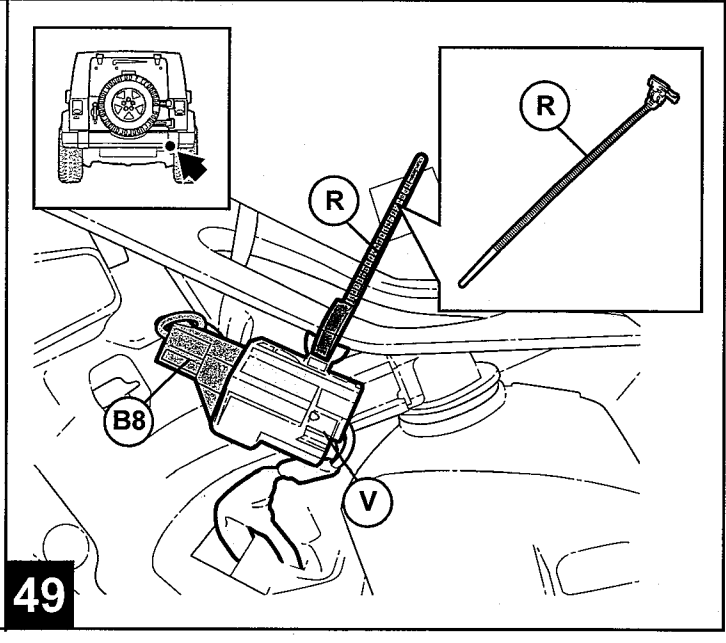
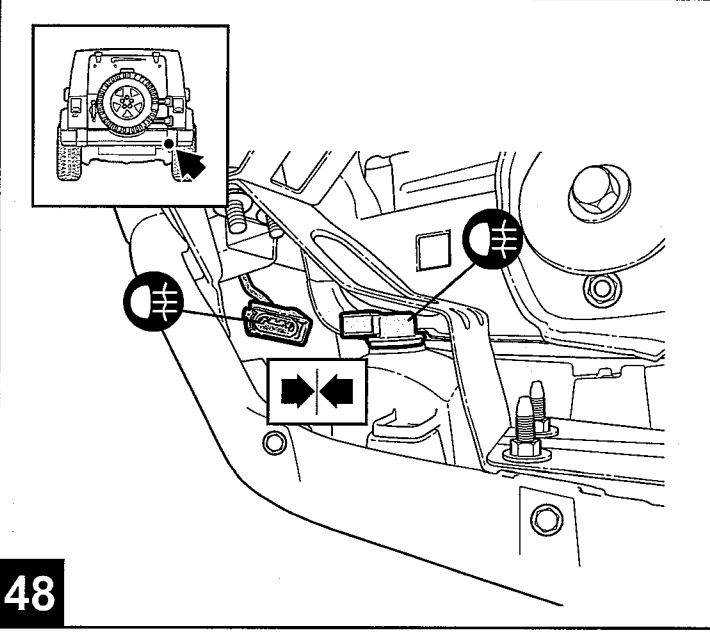
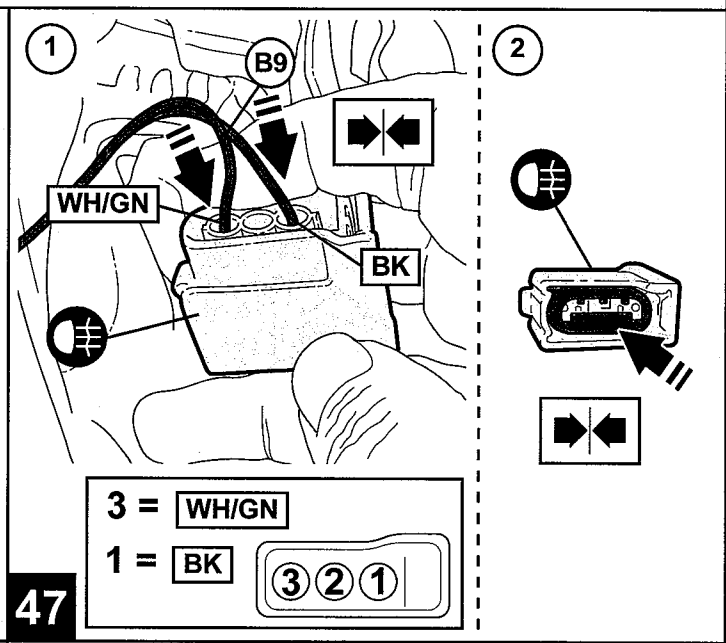
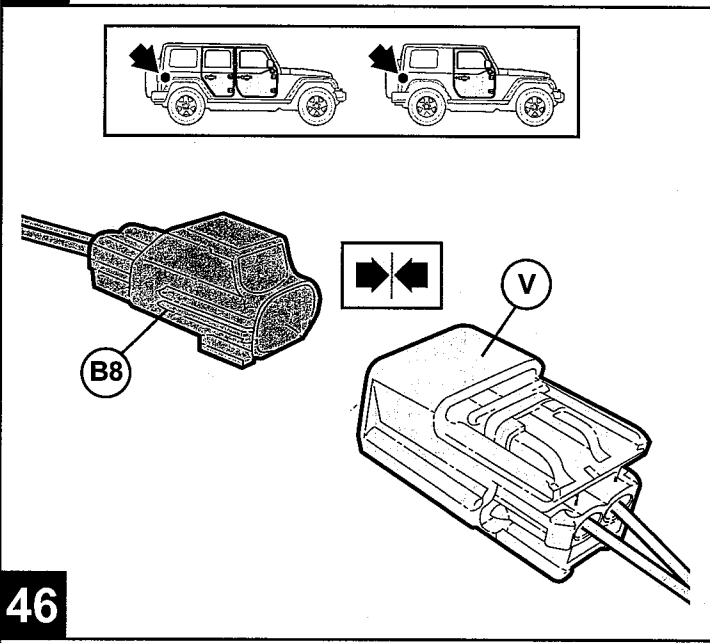
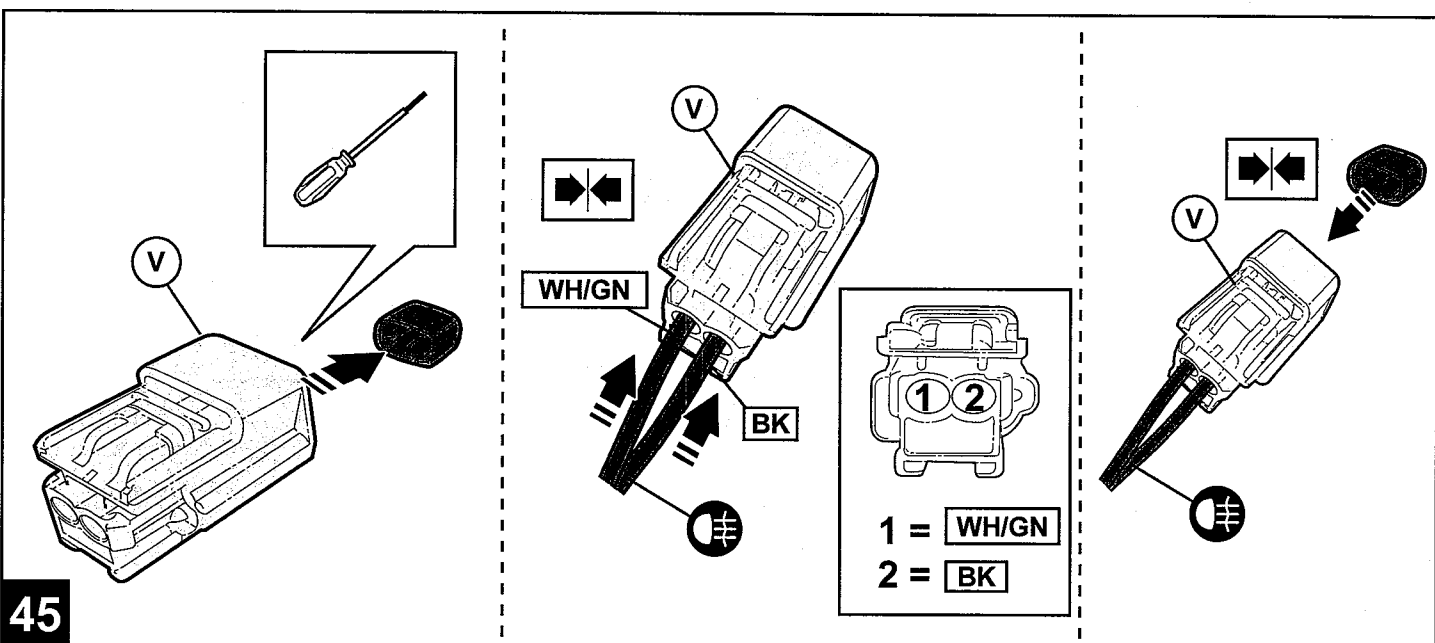

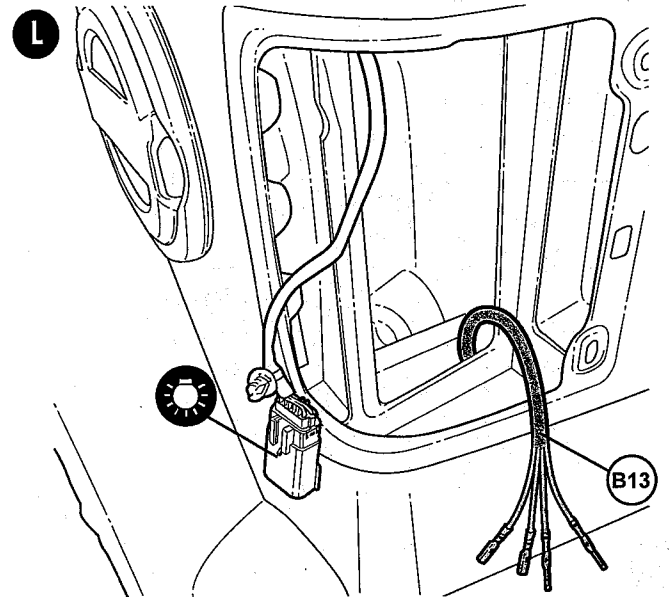
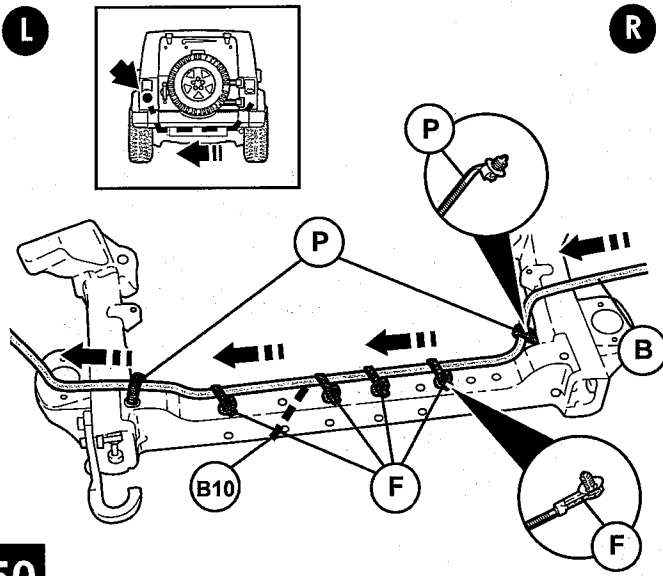

50

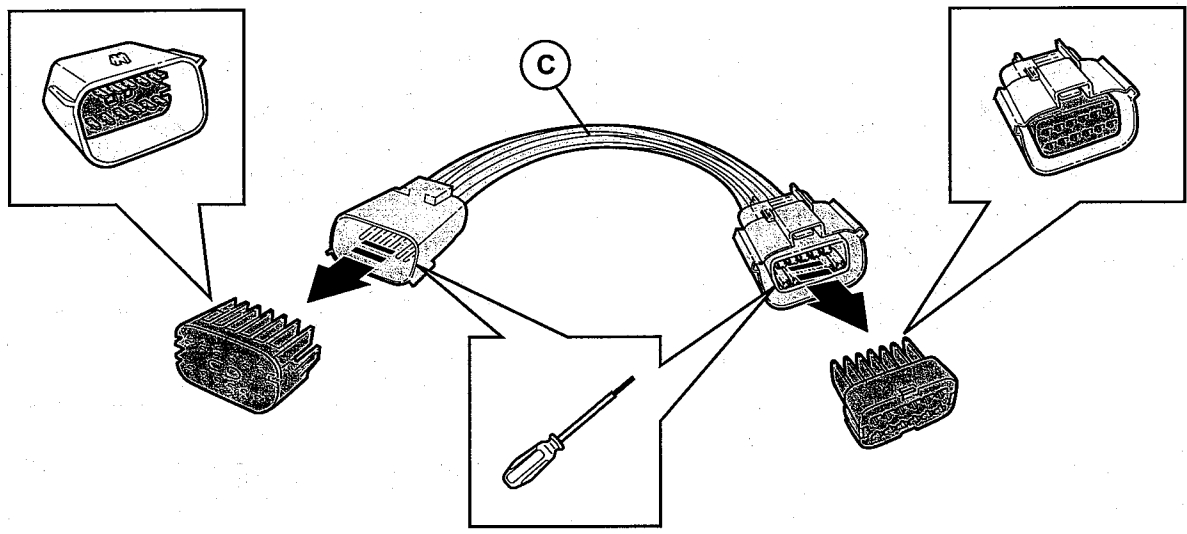

51

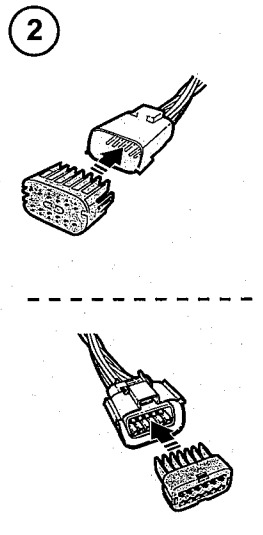
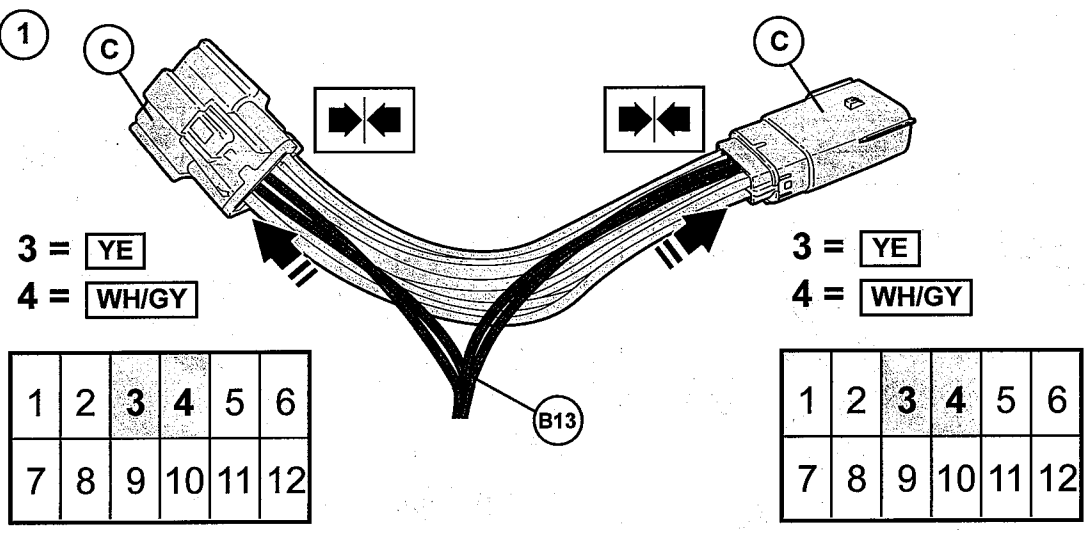

52

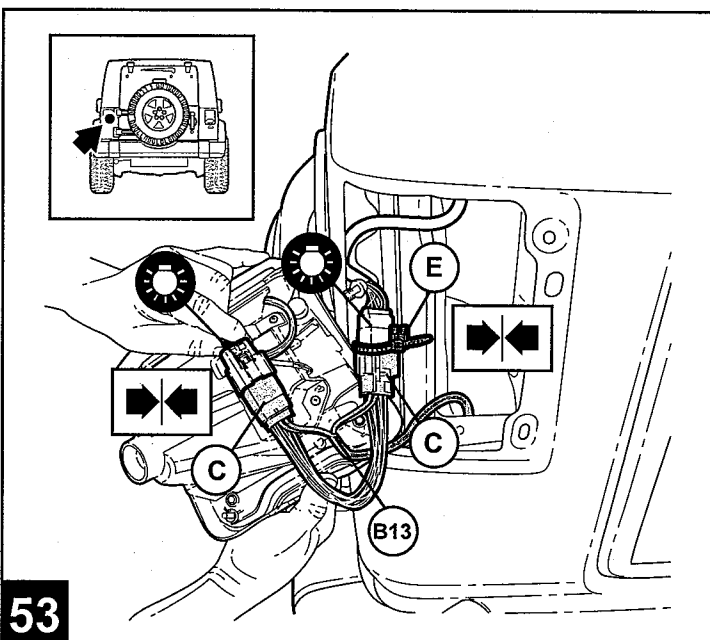

53

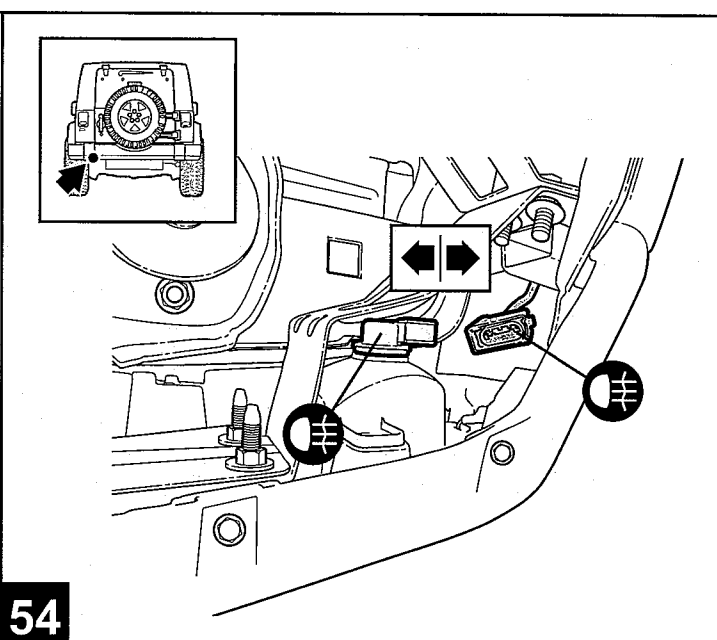

54

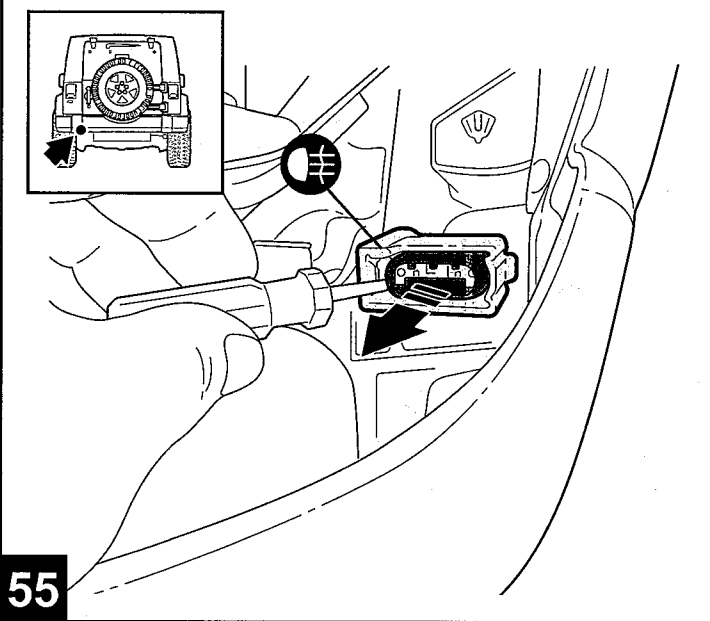

55

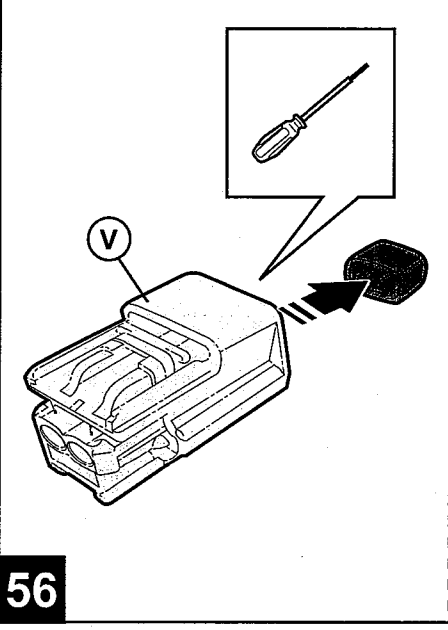
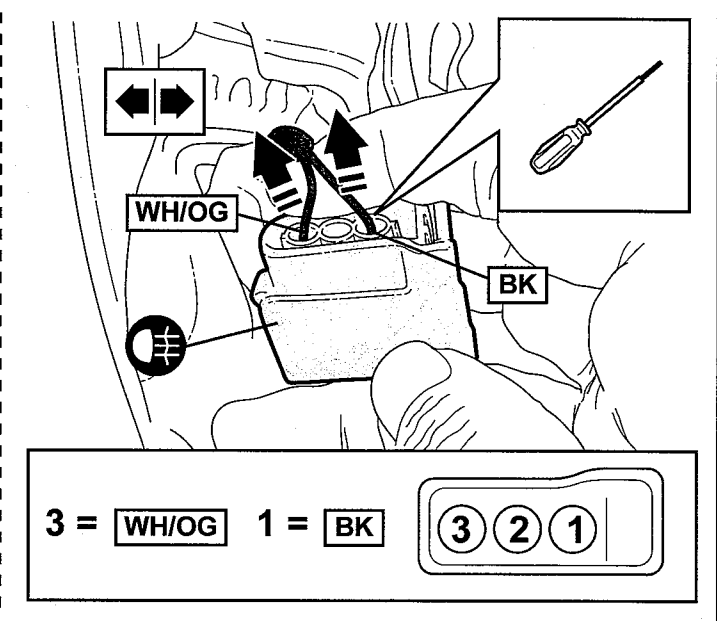

56

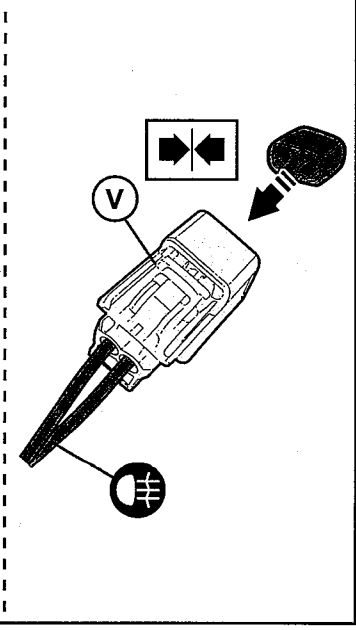
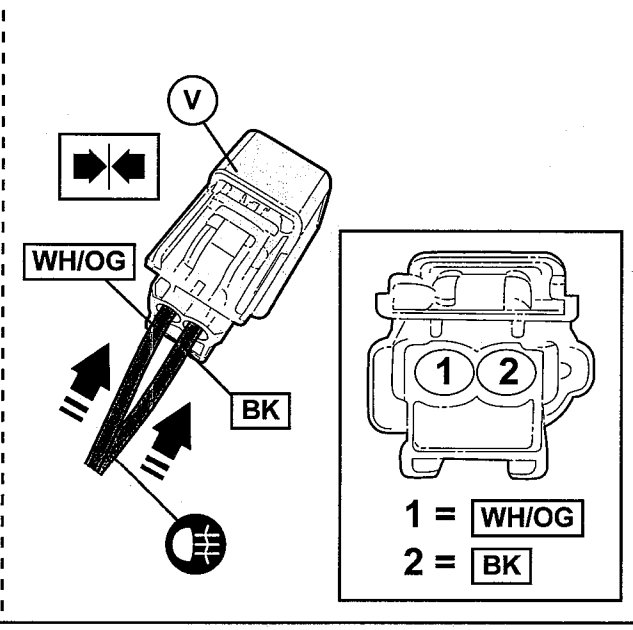

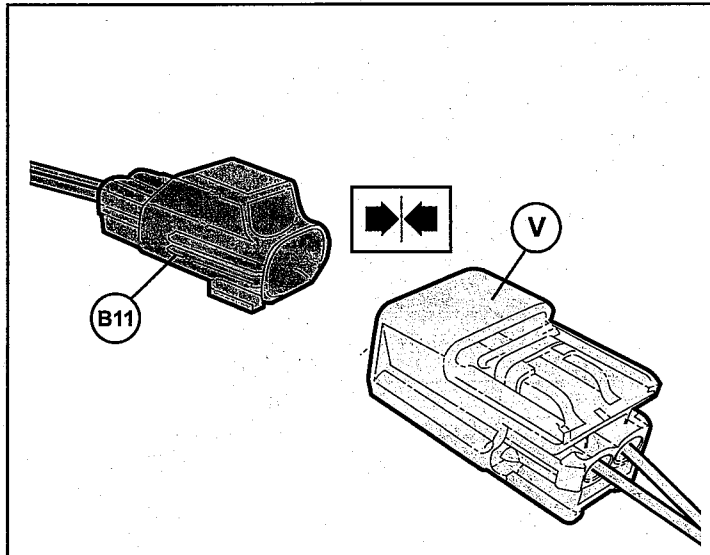

57

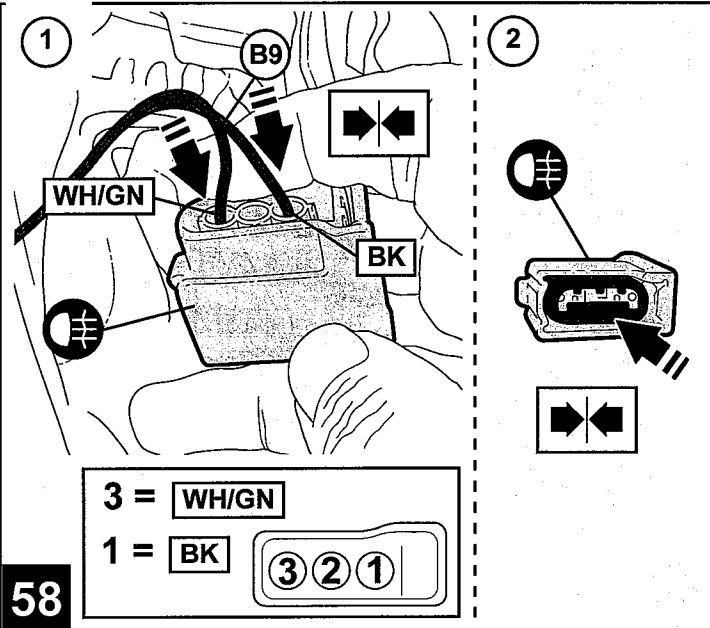

58

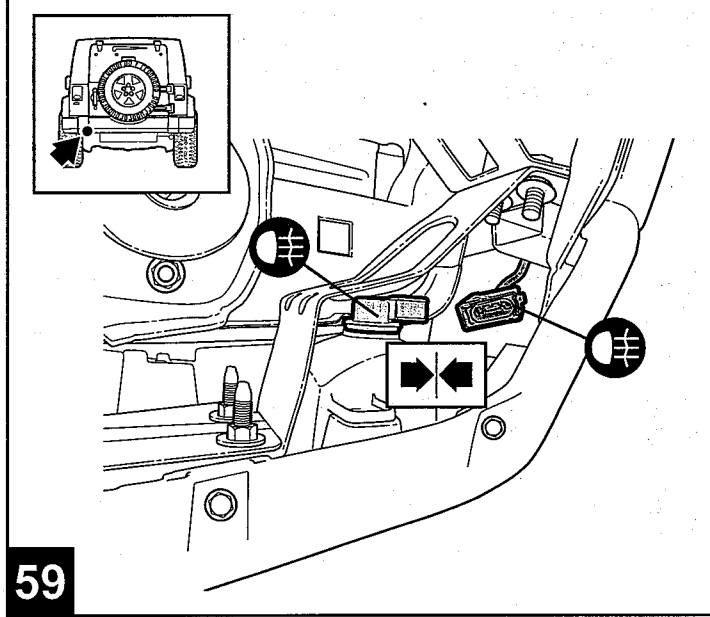

59

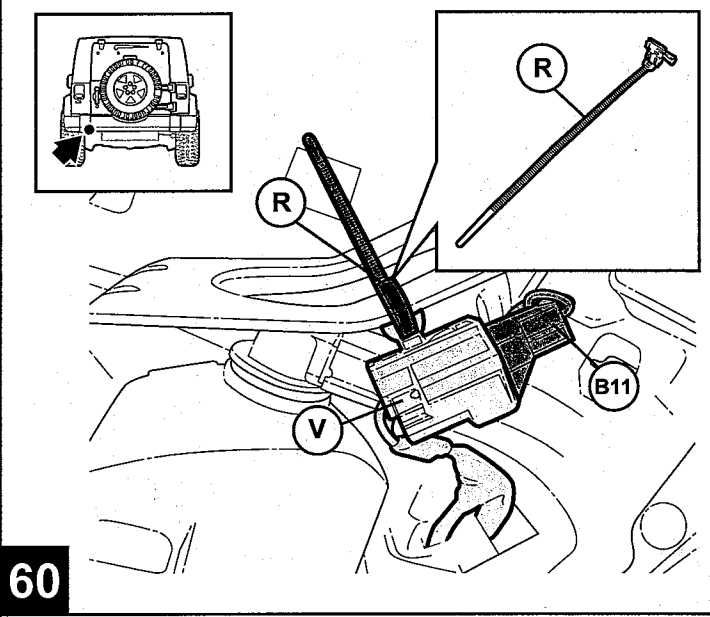

60

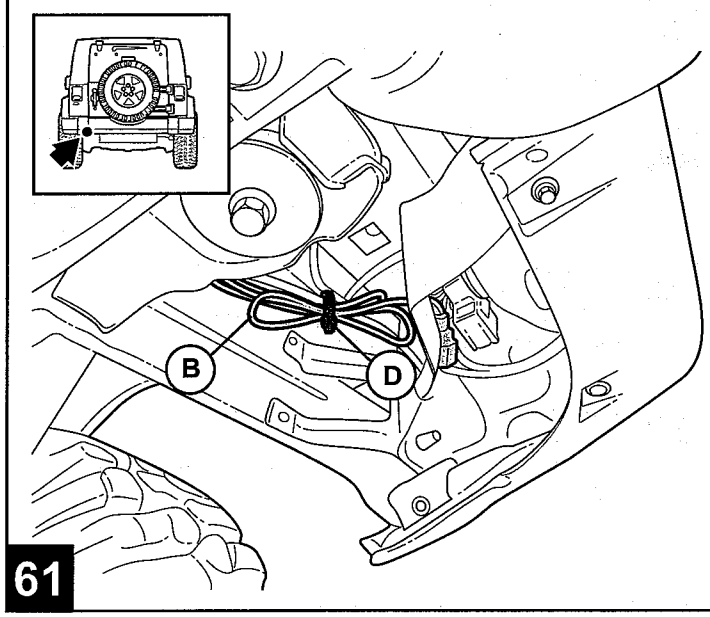

61

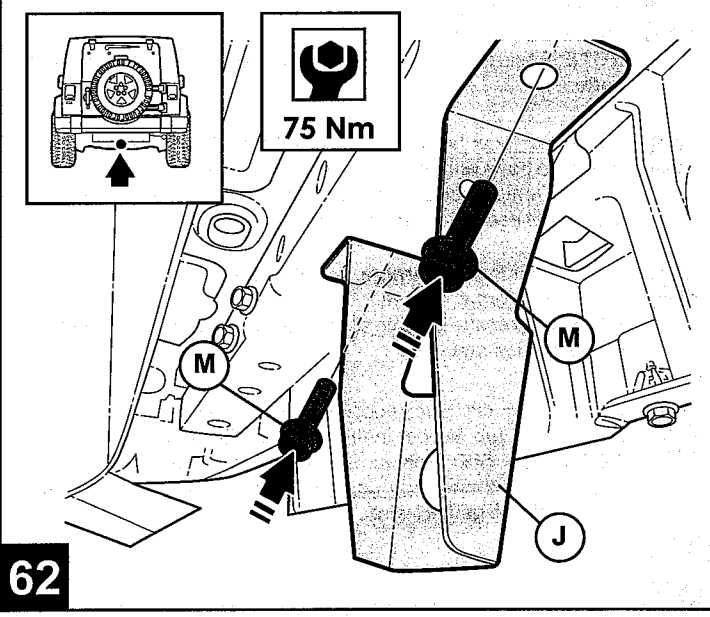

62

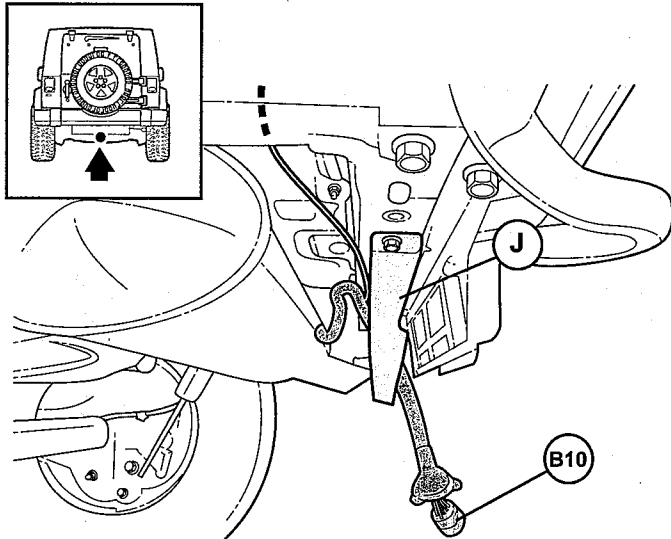

63

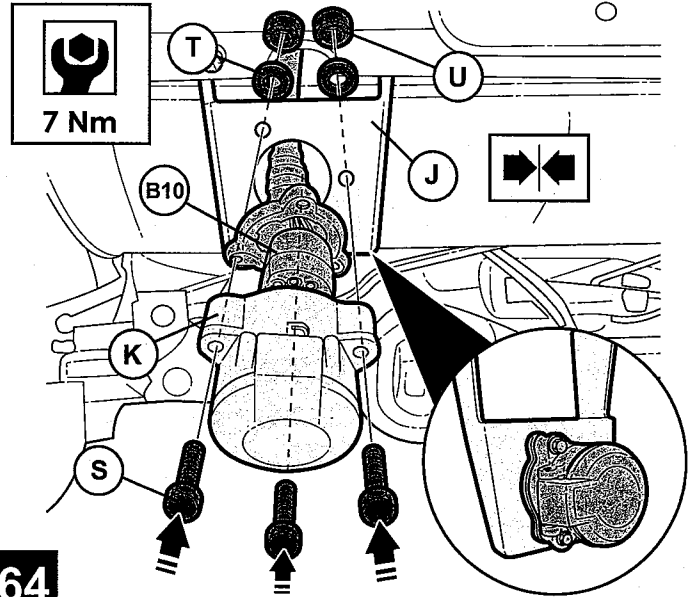

64

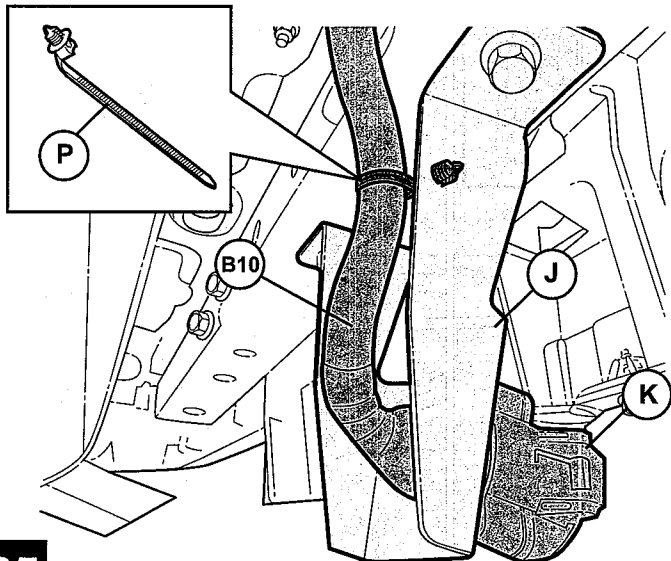

65

EN Re-attach the tail lamps, trims, and anything else that was removed in reverse order.
NOTE: Ensure harness routed away from exhaust and moving parts.

ES Volver a colocar las luces traseras, acabados interiores y todo lo que se haya retirado en orden contrario.
NOTA: Comprobar que el mazo de cables está alejado de las piezas del escape y otras móviles.

FR Rebrancher les feux arrière, garnitures et tout objet ayant été retiré dans l'ordre inverse.
NB: S'assurer que le câble soit éloigné du tuyau d'échappement et des parties mobiles.

DE Bringen Sie die Rückleuchten und alle anderen Teile, die entfernt wurden, wieder in umgekehrter Reihenfolge an.
BEACHTEN SIE: Achten Sie darauf, dass der Kabelbaum nicht in der Nähe der Auspuffanlage und von beweglichen Teilen entlang geführt wird.

66

GR Επανασυνδέστε με αντίστροφη σειρά τους οπίσθιους φανούς, τα ξακρίσματα και οτιδήποτε αφαιρέθηκε.
ΣΗΜΕΙΩΣΗ: Βεβαιωθείτε ότι οι δέσμες καλωδίων βρίσκονται μακριά από την εξάτμιση και τα κινούμενα μέρη.

RU Подсоедините задние фары, панели облицовки и все остальные снятые компоненты в обратном порядке.
ПРИМЕЧАНИЕ: Жгуты не должны касаться движущихся деталей и выхлопной системы.

PT Volte a colocar as lâmpadas traseiras, as tampas e tudo o que foi removido pela ordem inversa.
NOTA: Certifique-se de que o cabo está afastado do escape e das peças móveis.

ZH 按照与拆卸相反的顺序重新连接尾灯、镶边以及其它任何。
注意: 确保线束布线时避开排气管和运动件。

KO 테일 램프, 트림, 그 외에 제거했던 것들을 역순으로 재연결하십시오.
주의: 하네스는 배기구와 움직이는 부품에서 멀리 배치해야 합니다.

JA テールランプ、トリムその他を、取り外した時と逆の順序で再度取り付けます。
注意: ハーネスが排気および可動部品から離して配置されていることを確認します。

AR أعد تركيب مصباح الإنارة الخلفية، والملحقات، وأي شيء آخر كان قد تم وإالته بترتيب عكسي
ملاحظة: بلكد من توجيه حزمة الأسلاك بعيدا عن العادم والأجزاء المتحركة.

IT Rifissare i fanali posteriori, gli allestimenti e ogni altra cosa che sia stata rimossa in ordine inverso.
NOTA: Assicurarsi che il cablaggio sia posizionato lontano dallo scarico e dalle parti in movimento.

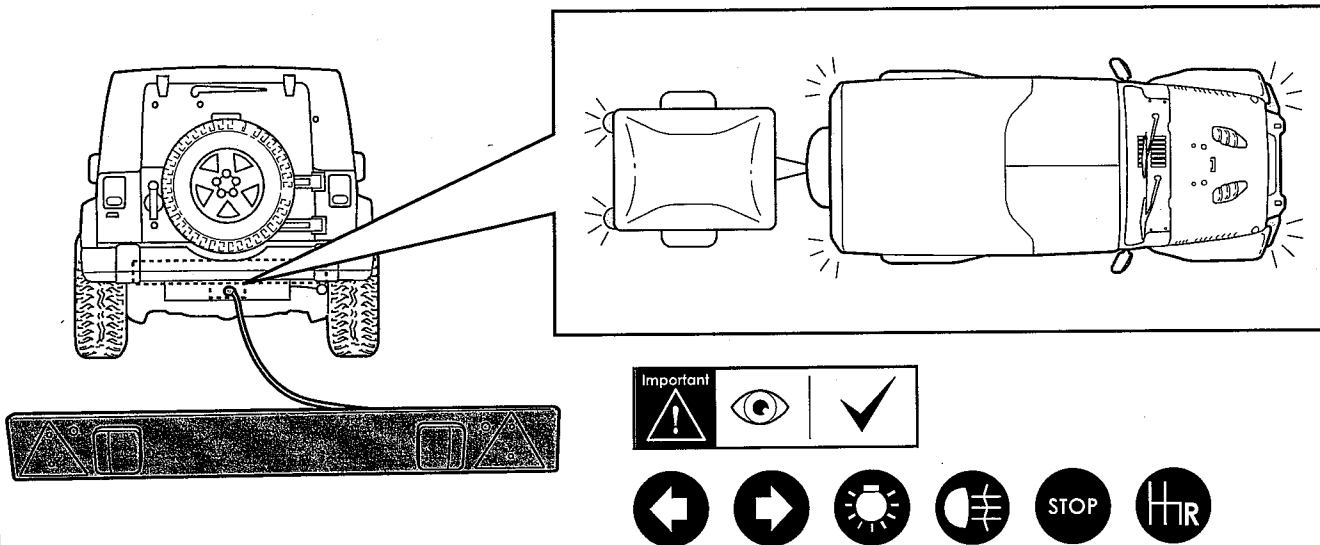

TR Arka lambaları, trimleri ve çıkarılan her şeyi ters sırada yeniden takın.
NOT: Kablonun, egzoz ve hareketli parçaların uzağından geçirildiğinden emin olun.

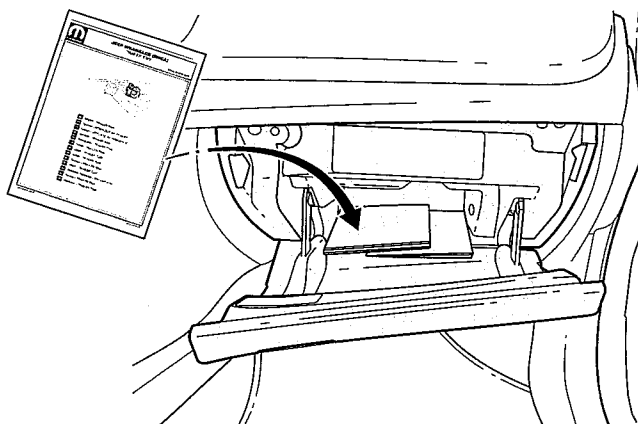

67



Document Revision History / Historial de revisión del documento / Historique des versions du document / Dokumentrevisionshistorie / Histórico de Revisão do Documento / Ιστορικό Αναθεώρησης Εγγράφου / Редакция документа / 文档修订记录 / 서 수정 이력 / 文書改訂履歴 / تاريخ مراجعة الوثيقة / Cronologia modifiché documento/ Belge Düzelme Geçmişİ

		 Summary of Changes Made	